

DTSC-200A



DTSC-200A Unique Features

- ✓ Built on field proven DTSC-200
- ✓ New face plate with tactile buttons
- ✓ Large LCD display
- ✓ Programmable from HMI panel or service tool (USB connection)
- ✓ Shorter lead time

Automatic Transfer Switch (ATS) Controller

DESCRIPTION

The DTSC-200A (Digital Transfer Switch Control) controls the transfer of electrical power from one source to another for hospitals, data centers, office buildings, manufacturing plants and similar where lights out is not an option. The extremely versatile DTSC-200A ATS controller is easily configured for a wide range of automatic transfer switch applications including Main-Gen, Gen-Gen or Main-Main systems using circuit breakers or latching contactors. Source transfer can be performed as open, delayed, or closed transition with in-phase monitoring (synch check) that can be enabled for all transition types to ensure safe transfer. The closed transition overlap time can be limited to less than 100ms for momentary, make-before-break transfers, or extended indefinitely for paralleling via discrete input. "Custom" features like transfer inhibit, source selection, load shed/restore, elevator pre-signal and engine test programs come standard.

LogicsManager™ - Programmable Boolean logic functions along with ample, expandable discrete I/O allows for complex transfer schemes without using external relay logic or a separate PLC!

FlexApp™ - Easily configures the DTSC-200A for: Utility-to-Generator, Generator-to-Generator or Utility-to-Utility applications

DynamicsLCD™ - The adaptive and interactive 4.3", 480 x 272-pixel TFT LC display with tactile buttons and a clear menu structure ensure intuitive user operation and navigation.

FEATURES

- True R.M.S. 3-phase voltage measuring for both Source 1 and Source 2
- True R.M.S. 3-phase load current/power
- Software configurable for wide range of ATS applications:
 - Utility-to-Generator: Utility is preferred with a generator as emergency source
 - Generator-to-Generator: One genset is preferred with a second genset as backup
 - Utility-to-Utility: Utility is preferred with second utility as the emergency source
- Incorporates several monitoring features for a secure transfer: Source, Load, Switch, Battery, In-phase, and parallel time monitor
- Intelligent limit switch feedback monitoring to ensure plausibility before initiating a transfer
- Fully configurable transfer command pulse configuration
- Inhibit transfer to S1, S2, both or start emergency source but initiate no transfer
- Elevator pre-signal with timer before carrying out a transfer
- Motor load disconnect signal with timer and possibility to daisy chain multiple MLDs for load sequencing
- Source priority selection configurable via LogicsManager
- Load test and engine test to initiate routine health check of the emergency source
- In-phase monitoring ensures a transfer occurs within a phase angle difference of 7° or less
- Extended parallel time enables soft loading applications
- Vector group adjustment if transformers are used in the ATS system
- Shunt trip enable signal ensures both sources are not paralleled for more than desired time
- Remote control via interface (CANopen, Modbus RTU) and via discrete inputs
- I/O expansion capability (additional 16x DI and 16x DO supported via IKD1M or 3rd party modules)
- Adjustable display backlight shutdown to reduce power consumption
- Woodward ToolKit™ software for flexible setup from a single connection to the network. Supports settings file created from the DTSC-200
- Multi-lingual capability: English, German, Spanish, Polish, Russian, other languages upon request

- Premium ATS control for complex transfer switch applications for critical power assets. Supports,
 - Circuit breakers or latching contactors
 - Open, delayed, or closed transition transfer
 - Make-before-break (<100ms) transfer or extended indefinitely for paralleling
 - In-phase monitoring (synch check) for all transition types
 - Engine exerciser (load/no-load) routine with fully adjustable interval
 - Load shed and restore
 - Elevator pre-signal
 - Transfer/return inhibit
 - Adjustable timers and bypass
 - Priority source selection
 - Freely configurable, expandable discrete I/O
 - CANopen / Modbus RTU
 - PC and/or front display configuration with password protection
- CE marked
- UL/cUL 1008

SPECIFICATIONS

Power supply	12/24 V _{DC} (8 to 35 V _{DC})	Discrete outputs group A [R 2-4]	isolated
Intrinsic consumption	max. 6 W (standby max. 5 W)	Rated 7 A _{DC} , 24 V _{DC} running standalone
Ambient temperature (operation)	-25 to 70 °C / -13 to 158 °F	Rated 3 A _{DC} , 24 V _{DC} when running in parallel with other two relays
Ambient temperature (storage)	-25 to 70 °C / -13 to 158 °F	3 A _{DC} , 24 V _{DC} resistive GP (according to UL6200)
Ambient humidity	93%, non-condensing	Discrete output [R 5]	isolated
Voltage	$\sqrt{\Delta}$	Rated 7 A _{AC} , 250 V _{AC} voltage free output, resistive GP
Rated (V _{rated})	277/480 V _{AC}	Discrete outputs group B [R 6-7]	isolated
Max. value (V _{max})	358/620 V _{AC}	Rated 10 A _{DC} , 24 V _{DC} running standalone
Max. value (V _{max}) according to UL6200	173/300 V _{AC}	Rated 5 A _{DC} , 24 V _{DC} when running in parallel with the other relay
Accuracy	Class 1	2 A _{DC} , 24 V _{DC} inductive (according to UL6200)
Linear measuring range	1×V _{rated}	Discrete output group C [R 8-9]	isolated
Measuring frequency	50/60 Hz (40 to 85 Hz)	Rated 7 A _{AC} , 250 V _{AC} voltage free output, resistive GP
High Impedance Input; Resistance per path	4.0 MΩ	Interfaces	
Max. power consumption per path	< 0.2 VA	USB service port	
Current (Isolated) Rated (I_{rated})	5A	Max. allowed cable length	1.5 m
Linear measuring range	I _{gen} = 2.0×I _{rated}	RS-485 interface	isolated
	I _{mains/ground} = 1.5×I _{rated}	Insulation voltage	500 V _{AC}
Rated short-time overcurrent (1 s)	10×I _{rated}	Max. allowed cable length	1000 m
Accuracy	Class 1	CAN bus interface	isolated
Discrete inputs group A [DI 1-7]	non isolated	Insulation voltage	500 V _{AC}
Low level threshold	Approx. 1.3 V _{DC}	Internal line termination	120 Ohm
High level threshold	1.7 V _{DC}	Housing Front panel flush mounting	Plastic housing
Max. input voltage	60 V _{DC}	Dimensions WxHxD	237 × 172 × 45 mm
Min. input voltage	0 V _{DC}	Front cutout WxH	214.5 × 160.5 mm
Discrete inputs group B [DI 8-12]	non isolated	Connection	screw/plug terminals 2.5 mm ²
Low level threshold	Approx. 1.3 V _{DC}	Front	insulating surface
High level threshold	1.7 V _{DC}	Sealing Front	IP65 (with screw fastening)
Max. input voltage	24 V _{DC}	Back	IP20
Min. input voltage	0 V _{DC}	Weight	approx. 0,850 g
Display		Disturbance test (CE)	tested according to applicable IEC standards
.....	480 × 272 TFT LCD with backlight	Listings	CE, UL1008 (File No: E527936)
.....	Wear resistant and scratch resistant LCD due to hard acrylic screen		

DIMENSIONS

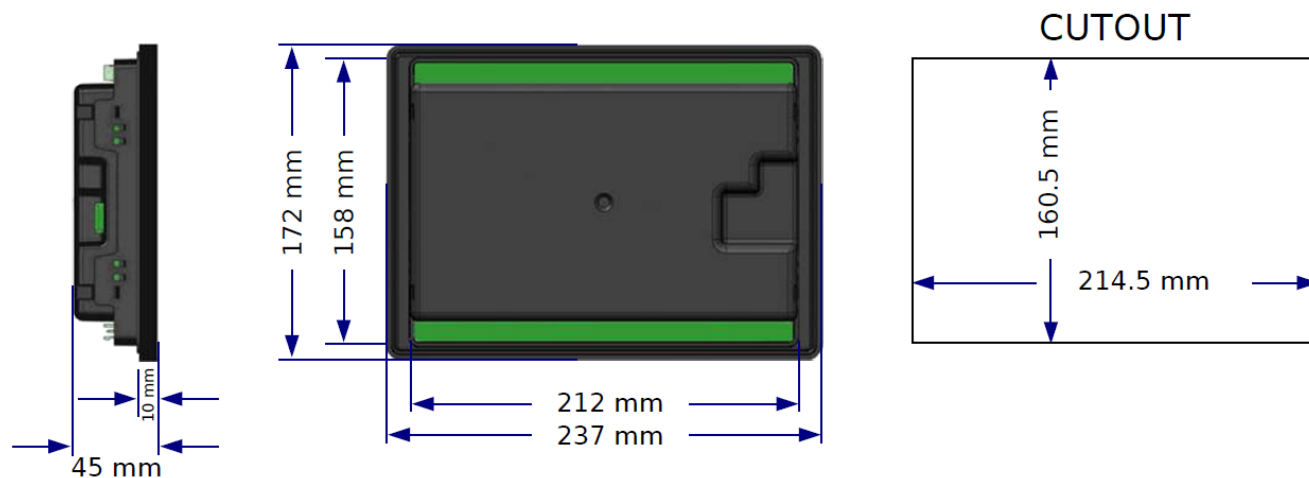

TERMINAL DIAGRAM

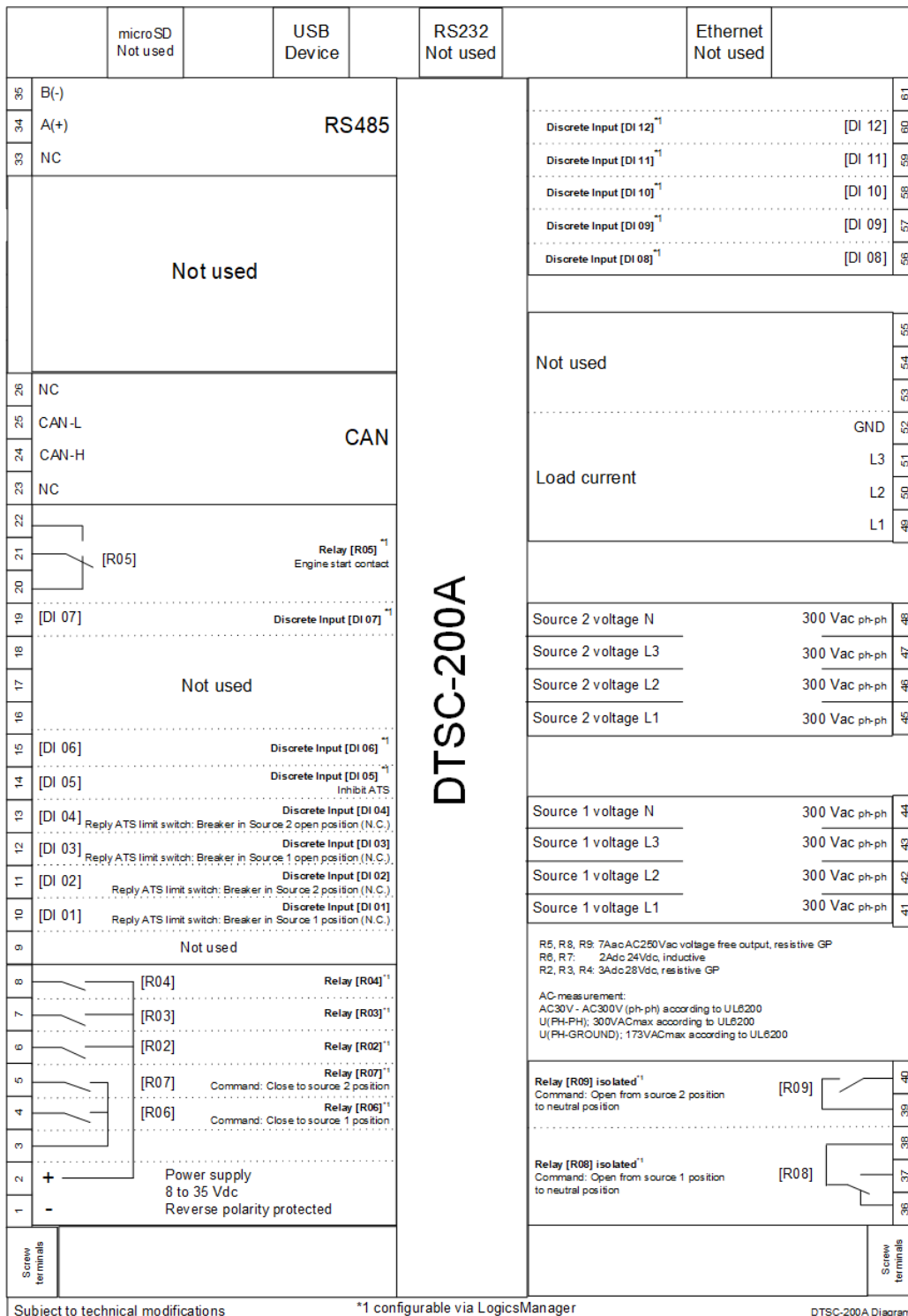

RELATED PRODUCTS

- I/O Expansion Board **IKD1** (Product spec. # 37171)
- **ToolKit** (Product spec. # 03366)
- Genset controller **easYgen-3200XT** & **easYgen-3500XT** (Product spec. # 37582 and #37583)
- Circuit breaker controller **easYgen | LS-6XT** (Product spec. #37913)
- CANbus to Fiber Optic Converters (Application note # 37598):
DL-CAN P/N 8445-1049 and **DL-CAN-R** P/N 8445-1048
- Remote Access Gateway (with HMS Netbiter **EasyConnect EC250** and **EC350**)
- Phoenix expansion CAN Couplers



CONTACT

North & Central America
Tel.: +1 (208) 278 3370

South America
Tel.: +55 19 3708 4800

Europe
Tel.: +49 711 78954 510

Middle East & Africa
Tel.: +971 2 678 4424

Russia
Tel.: +49 711 78954 515

China
Tel.: +86 512 8818 5515

India
Tel.: +91 124 4399 500

ASEAN & Oceania
Tel.: +49 711 78954 510

SALES SUPPORT
✉ industrial.sales.PG@woodward.com

TECHNICAL SUPPORT
✉ industrial.support@woodward.com

www.woodward.com

Subject to alterations, errors excepted.

Subject to technical modifications.

This document is distributed for informational purposes only. It is not to be construed as creating or becoming part of any Woodward Company contractual or warranty obligation unless expressly stated in a written sales contract.

We appreciate your comments about the content of our publications. Please send comments including the document number below to stgt-doc@woodward.com

© **Woodward**
All Rights Reserved

For more information contact:



MSHS.COM

SALES@MSHS.COM

800.622.6747

B37944 - 2022/05/Stuttgart

Digital Transfer Switch Controller		DTSC-200A
Measuring		
True R.M.S. Source voltage (3phase/4-wire)	Source 1	✓
	Source 2	✓
Load current (3phase/4-wire, true RMS)	.../5 A	✓
Breaker Control		
Open transition (break-before-make)		✓
Delayed transition (break-before-make) + timed neutral position		✓
Closed transition (make-before-break) #1		✓
Application <i>FlexApp™</i>		
Utility to generator		✓
Utility to utility (configurable phase angle)		✓
Generator to generator (2 start signals)		✓
Features		
Programmable elevator pre-signal		✓
Programmable motor load disconnect signal		✓
Transfer commit		✓
Test modes #2		✓
Transfer mode selector #2		✓
Load shed #2		✓
Shunt trip enable #2		✓
Extended parallel time #2		✓
Automated display backlight shutdown selectable		✓
Daylight saving time		✓
Source priority selection #2		✓
Vector group adjustment for in-phase monitoring		✓
Fully adjustable timers #3		✓
Status LEDs for source availability and breaker state		✓
Accessories		
Tactile keys (advanced LC display)	<i>DynamicsLCD™</i>	✓
Configuration via PC #4		✓
Event recorder with real time clock		300
Flush-mounting (screw or clamp fastening)		✓
Monitoring ANSI#		
Source: voltage	59/27	✓
Source: frequency	810/81U	✓
Source: voltage asymmetry	47	✓
Source: rotation field		✓
Load: overload	32	✓
Load: overcurrent	50/51	✓
Switch: plausible switch position		✓
Switch: transition failure		✓
Battery: voltage		✓
Synch check (in-phase monitoring)	25	✓
Parallel time monitoring		✓
I/Os		
Discrete inputs (configurable)		12
Discrete outputs (configurable)	<i>LogicsManager™</i>	8
USB service port #4		✓
CANopen communication bus (isolated)		✓
RS-485 Modbus RTU Slave half-duplex (isolated)		✓
Listings/Approvals		
UL/cUL 1008 Listed		✓
CE Marked		✓
Part numbers		
Front panel mounting with display, 5A CT input#5		8440-2297
Spare connector kit		10-004-675

#1 Optimized to achieve short parallel (< 100ms) or extended long parallel as per LM status

#2 via internal conditions or remote command

#3 neutral delay timers (1 to 6500 s), elevator pre-signal timers (1 to 6500 s), motor load disconnect timers (1 to 6500 s), stable timers (1 to 6500 s), outage timers (0.1 to 10.0 s), engine start delay timers (1 to 300 s)

#4 Configuration software 'Toolkit' available free at Woodward.com or at product documentation site, <http://wwdmanuals.com/dtsc-200a>

#5 a screw and a clamp kit are delivered with the unit for fastening