

RSP 305 Remote Panel

Introduction

RSP 305 is the correct choice for remote monitoring and control of diesel engine control panels type DCU 305. Up to four DCU 305 units can be connected to one RSP 305 Remote Panel.

The RSP 305 Remote Panel will shorten project time frames because of the automatic configuration feature.

It has the same high contrast/easy readable screen as the DCU 305.

The information is presented in exactly the same fashion as on the DCU 305. A common user interface locally in the wheelhouse and remote in the engine room makes it easier for the operator. All commands such as Start, Stop, Standby / Manual and Reset are available.

The informative Engine Overview page displays the most important information from each engine. The operator can choose to zoom in at any of the engines, giving the same view as on the DCU 305 unit.

Automatic Configuration

The RSP 305 configures itself completely automatically by reading the configuration in all the connected DCU 305 units. This means the RSP 305 is immediately ready for use without any need for lengthy field configuration.

Communication

The RSP 305 is connected to the communication port of one or several DCU 305 units. The link is a 4-wire twisted pair cable. Selfconfiguring RS-232/RS-422 signal converters are used.

Alarm List

The common Alarm List displays alarms from all engines in the network, and the operator can choose to sort them chronologically, per engine or by severity. Alarms can be acknowledged and are kept in the log.

Log

The built-in log stores and displays all alarms.

Compatibility

RSP 305 is compatible with all DCU 305 units.



Features

- Self-configuring remote panel compatible with the DCU 305 range of control units.
- Easy access to common alarm list.
- Monitor and control of up to four DCU 305 engine control units.
- Commands for Start, Stop, Acknowledge alarms, Standby and Manual mode.
- Half light, and Night modes.
- Historical log of all events.
- Backlit graphical LCD.

Ordering Info

Item	Article #
RSP 305 Remote Panel	06500
Signal converter RS-232/RS-422, self-configuring	08335
Cable between RSP 305 and signal converter, 200 cm	08226
Cable between DCU 305 and signal converter, 60 cm	08227
MK-6 Relay Unit	75262
MK-14 Relay Unit	75263



Sophie Radichs vei 7
NO-2003 LILLESTRØM
Norway
Telephone: (+47) 64 84 52 00
Telefax: (+47) 64 84 52 12
E-mail: office@auto-maskin.no

www.auto-maskin.no

System overview

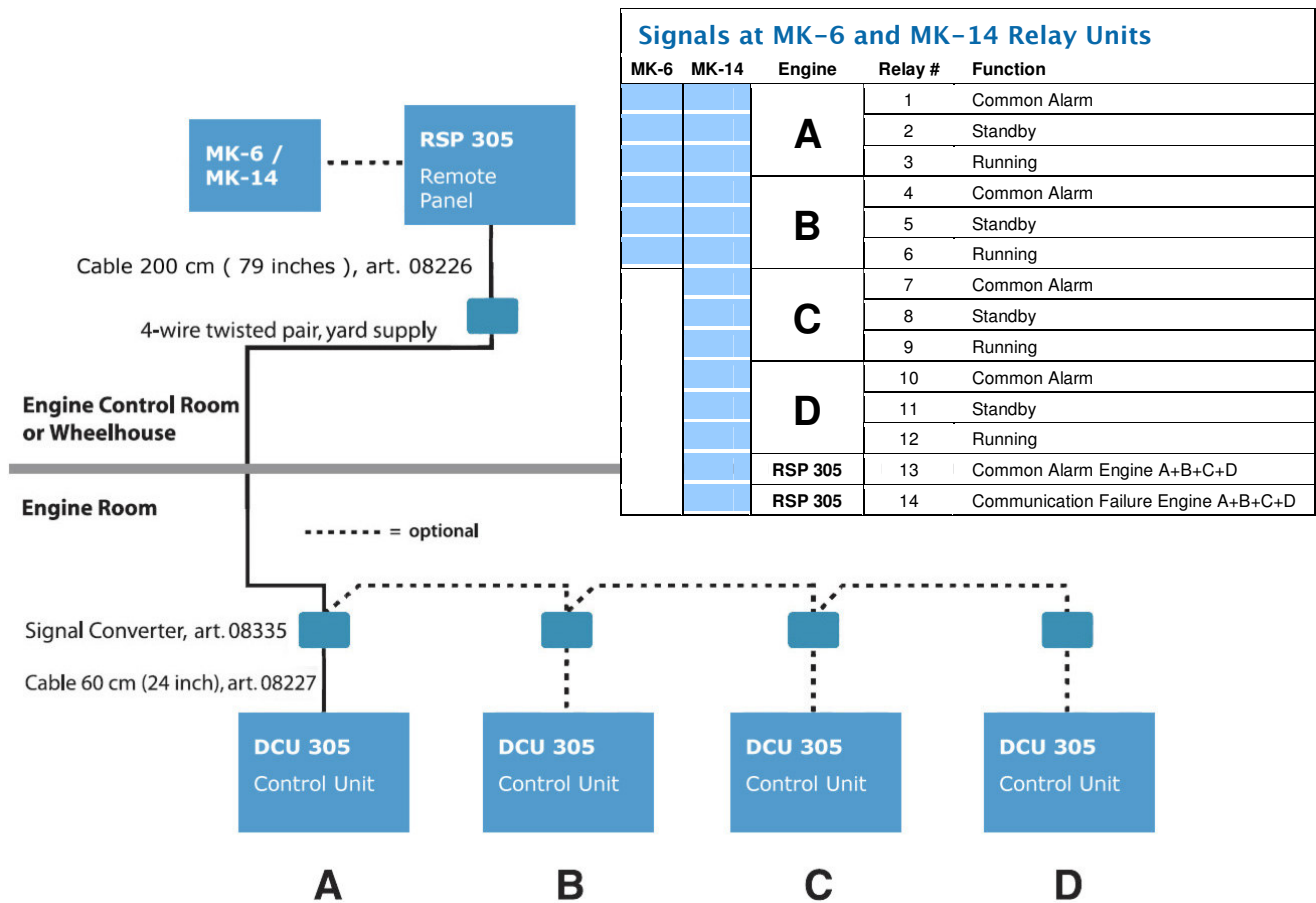

Technical Specification	
Item	Particulars
Overall dimensions	160 x 260 x 35 mm (6.3 x 10.2 x 1.4 inch) [H x W x D]
Cut-out dimensions	146 x 230 mm (5.8 x 9.1 inch) [W x H]
Supply voltage	24 V smoothed (20 – 30 V DC)
Number of DCU 305 units that can be connected	1 - 4
Compatibility	DCU 305 R1 / R2 / R3 (R1 ver. ≥ 2.1)
Communication cable max length (yard supply)	1200 meter (3900 feet)
Communication speed	9600 Baud
Current Consumption	< 400 mA
Automatic configuration	< 60 sec
Power-on to Ready (when configured)	< 5 sec / DCU 305
Weight	1250 g (2.75 pounds)
Ambient Temperature in operation	0 – 70 °C (32 – 158 F)
Air Humidity in operation	< 90 %



RTNA



Germanischer Lloyd

