



At a glance

- Phase and line voltages up to 520VAC
- Phase to neutral voltages up to 300VAC
- Phase currents
- Frequency
- Power factor
- Total KW electrical
- Local LED display aids installation and troubleshooting
- Configurable turndown ratios
- Provision for single 85 – 265V max power supply

Why customers select the RIO 425

- Provides flexibility to integrate differing applications into a standard package
- Connects to DCU via simple two wire twisted pair
- Displaying AC parameter on DCU eliminates need for separate AC panel
- Can be placed in alternator terminal box to reduce complex wiring runs
- “Plug and Play” when linked to a DCU
- Easy to configure to whatever CT / PT’s present
- No on site configuring required
- No dedicated software or cables required
- Simple installation and commissioning

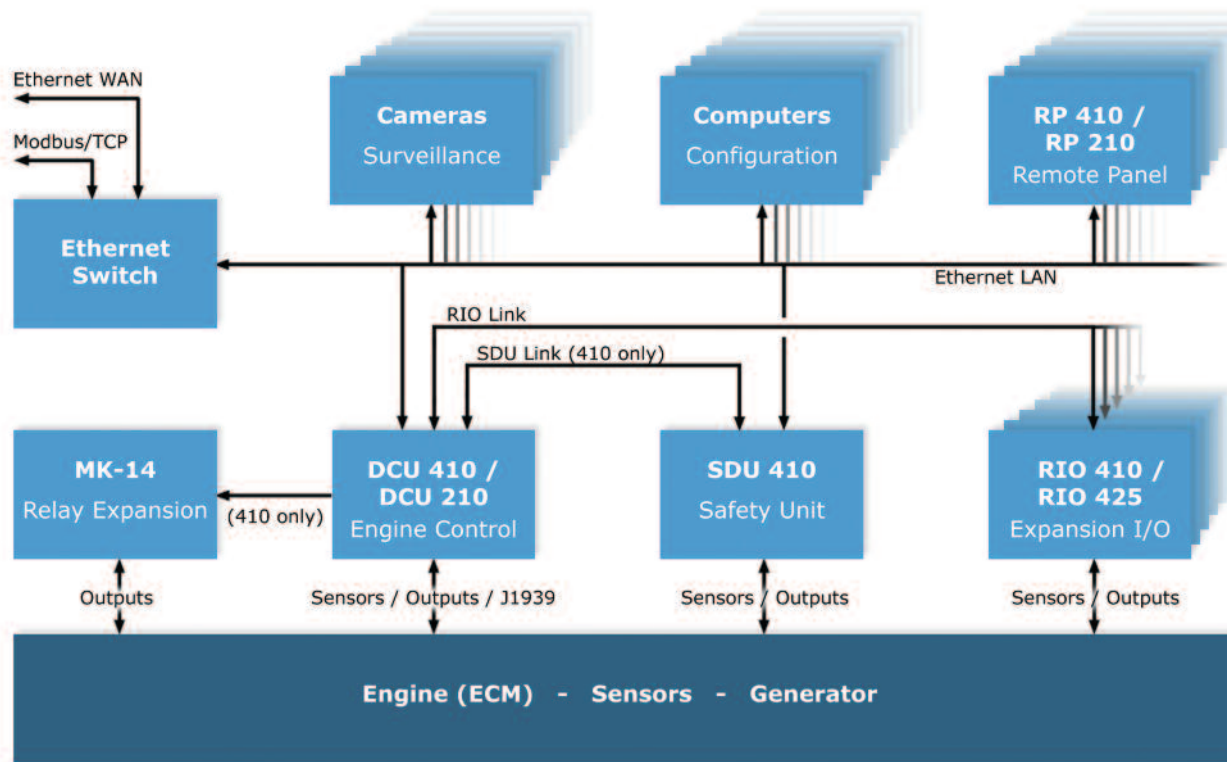

Features and Benefits

Simplified Generating Set build

- One supervision panel required
- Use of standard current and voltage transformers
- DIN rail mounting
- Single point sourcing
- Reduced wiring scope

Simplified Installation

- Easily configured turndown ratios
- Mounted in terminal box with simple two wire twisted pair connection to DCU
- Integrated Unit display on RIO 425 aids installation
- Common communication reduces interfaces

Ease of Communication

- Modbus communication to DCU via just two wires
- Configurable turn down ratios
- Configurable display on DCU and RP 410 units

Ability to Network

- Automatically configured by DCU
- Allows data to be placed upon an Ethernet network
- Single point for Alternator integration
- Ability to provide clear and immediate service data

Technical and Production

Auto-Maskin AS
 Sophie Radichs vei 7
 NO-2003 Lillestrøm, Norway
 Tel.: +47 64 84 52 00
 Fax: +47 64 84 52 12
 E-mail: office@auto-maskin.com
 Web: www.auto-maskin.com

Ordering Info

Item	Part Number
DCU 410	1006450
DCU 408	1006455
SDU 410	1006451
RIO 410	1006453
RIO 425	1006457
RP 410	1006452
MK-14	1121252