

### At a glance

- Single power supply can accept 12V or 24V
- 10 channels for configurable switch inputs
- 2 channels configurable for 4-20mA inputs
- 2 channels configurable for PT100 inputs
- 6 Configurable 24V outputs
- 2 Configurable relay outputs
- Single magnetic pickup
- USB memory interface
- J1939 CANbus
- Data port outputs for Ethernet and Modbus TCP or RTU

### Why customers select the DCU 208

- Reduced cost in unattended engine spaces requiring no local panel
- Single Ethernet cable and switch connectivity to a remote panel
- 11 languages changeable by one button at any station
- Accepts multiple sensor standards
- Compatible with all MarinePro remote panels
- Intuitively configurable using an Internet browser
- No special tools or cables required and includes a USB port
- Provides programmable engine control logic including auto and multi start
- Dedicated hardwired connections for critical engine functions
- All in one unit facilitates manufacturing compared to separate display / logic combinations

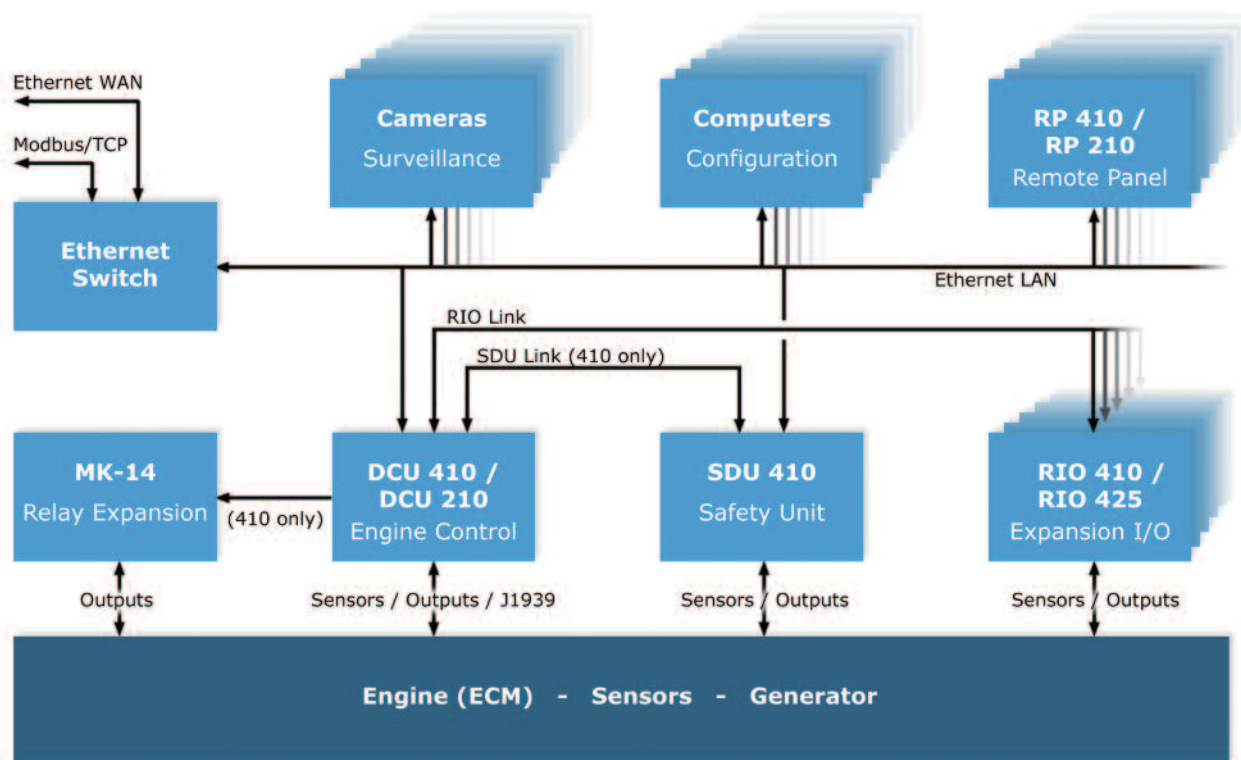

## Features and Benefits

### Same hardware for many applications

Can hold over 40 customer selectable configuration files via simple "Start Wizard"

- Ideally suited to small electronic engines or as a low cost alternative for mechanical engines

- Suitable for fixed and variable speed applications

- Multiple standard I/O's available

### No specialist skills for startup or installation

Pre printed connection function on units

- Simple connectivity – no special tools, web browser only software required

- Single unit simpler than separate CAN reader & logic units

- 11 Languages as standard including simplified Chinese and Russian

### Cost effective

Integrated display and logic reduces wiring and potential faults

- Can be used with an SDU 410 unit to provide a Restricted Class solution

- Mix and match with 400 units to align functionality needs

### Accountability

Historical event and alarm list

- Presents multiple data sources to a single point

- Engine faults in real text (where engine equipped)

- Links easily to Ships management or remote telemetry systems

## Technical and Production

Auto-Maskin AS

Sophie Radichs vei 7

NO-2003 Lillestrøm, Norway

Tel.: +47 64 84 52 00

Fax: +47 64 84 52 12

E-mail: office@auto-maskin.com

Web: www.auto-maskin.com

## Ordering Info

Item	Part Number
DCU 210	1006481
DCU 208	1006480
RP 210	1006482
DMU 206	1006483