

TecJet™ 50 Plus Precision Flow Intelligent Electronic Gas Metering Valve

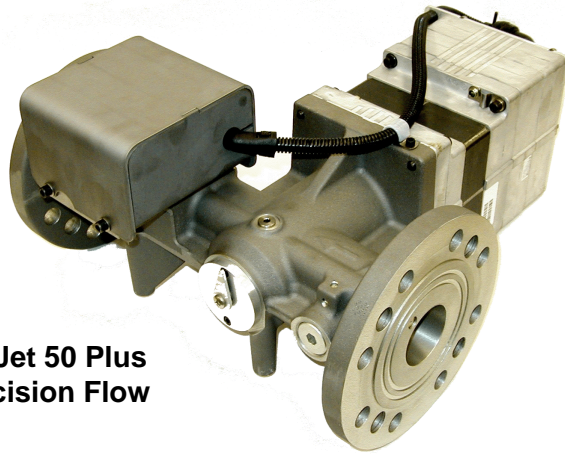

**TecJet 50 Plus
Precision Flow**

DESCRIPTION

EFFICIENCY, PERFORMANCE, AND EMISSIONS. In today's marketplace, these factors play a key role in gas engine development. As engine performance advances are made, gas metering devices should be more flexible and accurate, and be used for a wide range of gas qualities, from natural gas to propane.

Meet the TecJet™ valve. The TecJet is an electronic gas metering valve for single-point injection. It has integrated sensors and electronics, which provide the correct gas flow under all specified conditions.

In general, a separate engine control system, like the EGS-01 control, calculates the desired gas flow from the different engine and gas parameters. This desired gas flow is transmitted through a CAN link to the TecJet valve(s). The TecJet valve ensures that the desired gas flow is attained, automatically compensating for changes in gas pressure and gas temperature.

The microcomputer inside the TecJet valve converts the desired gas flow signal and gas parameter information into a valve position (which corresponds to the

desired gas flow), depending on gas inlet pressure, gas temperature, and the pressure difference across the valve.

BENEFITS

- Flexible inputs, so an OEM engine control system can be used. The EGS-01 is therefore not an absolute requirement. Communication in two directions possible with other control systems by means of the integrated CAN bus.
- Fast response to flow commands, which makes it possible to accept large load steps without losing engine speed.
- High turn-down ratio that makes it possible to use one TecJet model for a wide range of fuel flow requirements.
- The non-linear opening characteristics of the TecJet gas control valve enable you to control the gas flow at idle with accuracy and stability.
- Size: equivalent to Ø17 mm

- Forms ideal combination with EGS-01 control
- Microprocessor-based mass gas flow control
- Communication in two directions by CAN bus
- Fast response to flow commands
- Accurate over entire flow range
- Compensates for gas pressure and gas temperature fluctuations
- Integrated sensors and electronics
- Requires only analog or digital desired gas flow signal and supply voltage

APPLICATION

The TecJet™ valve, together with an engine control system, forms an ideal combination for operating gas engines with a gas specific gravity from 0.4 to 1.6. The TecJet 50 Plus Precision Flow gas control valve is applicable for stationary applications within a power range of 50 to 250 kW for pipeline-quality natural gas, or 50 to 380 kW for propane. Flow range is also dependent on other factors such as fuel pressure, fuel differential pressure across the valve, fuel temperature, etc. Consult the applicable TecJet Installation and Operation manual or a Woodward application engineer for actual sizing of a valve.

The TecJet gas control valve is typically installed upstream of the turbo. The TecJet has a fast response to handle variations in engine load and speed. This is important for good engine behavior, low fuel consumption, low emissions, and load changes. With the help of a PC (personal computer), you can easily monitor and set up the TecJet valve for your specific application.

ADJUSTMENTS

Using the TecJet Service Tool installed on a laptop or PC connected to the TecJet valve, you can monitor and make adjustments quickly and easily through the following six tabs:

- **Overview Tab**
The Overview Tab contains flow demand, gas pressures, gas temperature, and gas property information.
- **Troubleshooting Tab**
The Troubleshooting Tab contains typical valve information used for troubleshooting purposes. This information includes electronics temperature, supply voltage, running hours, and CAN communication info.
- **Warnings Tab**
The Warnings Tab displays valve warning indicators. When one of these warnings occurs, the valve continues to operate, but the valve Status Output switches to signal the operator that a problem has occurred.
- **Errors Tab**
The Errors Tab displays valve error indicators. When one of these errors occurs, the valve goes into shutdown mode, and the valve status output switches to signal the operator that a problem has occurred.
- **Configuration Tab**
The Configuration Tab allows the user to customize the valve to a particular application. CAN parameters, demand signal scaling, warning/error limits, default pressures, and demand source can all be viewed or changed on this tab.
- **Identification Tab**
The Identification Tab contains valve and software information such as part numbers and serial numbers.

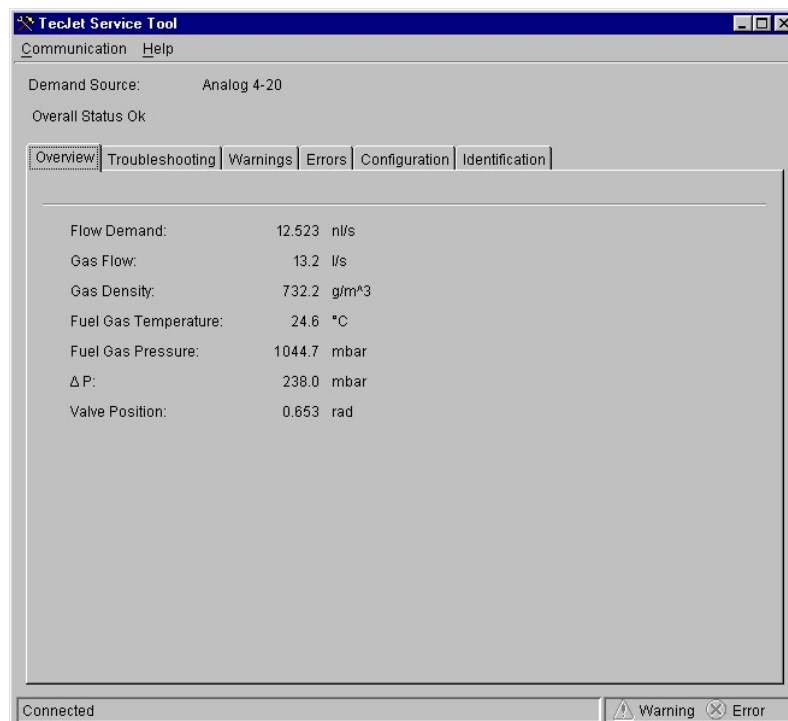

TecJet Monitoring Program

SPECIFICATIONS

Weight	24 kg (52 lb)
Valve Maximum Effective Area	181 mm ² (0.280 in ²) Range from 3.2 to 181 mm ² (0.005 in ² to 0.280 in ²)
Input Voltage Range	18–32 Vdc
Input Current Range	<=2.0 A steady state, 5.0 A peak
Temperature Ranges	
Steady State Ambient:	–20 to +85 °C (–4 to +185 °F)
Long Term Storage:	–40 to +40 °C (–40 to +104 °F)
Short Term Storage:	–40 to +105 °C (–40 to +221 °F)
Fuel Gas Inlet:	0 to +65 °C (+32 to +149 °F)
Pressure Ranges	
Fuel Gas Inlet:	876 to 1289 mbar absolute (12.7 to 18.7 psia)
Inlet to Outlet Delta:	51.7 to 276 mbar (0.75 to 4.00 psid, Delta lower than 51.7 mbar is allowed, but accuracy will degrade)
Filter in the Gas Stream	Maximum mesh size 50 µm
Flow Accuracy	±20% point accuracy -> Crank to 7% of valve maximum effective area ±10% point accuracy -> 7% to 25% of valve maximum effective area ±6% point accuracy -> >25% valve maximum effective area
Dynamics	
Position Loop Response:	–3 db at > 7 Hz, with 1400%/second slew rate limit, 2 ms dead time. Overshoot < 1%
Demanded Flow Response:	Same as position loop response with addition of 3 ms flow loop update rate
Pressure Change Rejection:	Same as demanded flow response with addition of 10 ms lag on P1 measurement, 140 ms lag on delta pressure
Vibration	Random Vibration: Exceeds WGC RV2, 10–2000 Hz @ 0.1 G ² /Hz (12.8 Grms)
Shock	Per US MIL-STD-810C, Method 516.2, Procedure 1 (40 g)
Communication/Command Signals	CAN PWM: 7 to 32 V differential input, 12 bit resolution, 40 kΩ impedance 4 to 20 mA Analog: 225 Ω impedance, differential, 25 mA ±2% max input current GECM: Customer specific input
Regulatory Compliance	
European Compliance for CE Mark: EMC Directive	Declared to 89/336/EEC COUNCIL DIRECTIVE of 03 May 1989 on the approximation of the laws of the member states relating to electromagnetic compatibility. Product also complies with the Machinery Directive and is exempt from the Pressure Equipment Directives.
North American Compliance:	CSA Certified for use in Class I, Division 2, Groups A, B, C, and D T3 for United States and Canada as a component for use in other equipment.
TecJet Service Tool	The TecJet Service Tool can be downloaded from the Web at www.woodward.com/software . Select software product “TecJet Tools”, then follow the installation instructions given on that page.
Technical Manual	26219 Installation and Operation Manual

PO Box 1519
 Fort Collins CO, USA
 80522-1519
 1000 East Drake Road
 Fort Collins CO 80525
 Ph: +1 (970) 482-5811
 Fax: +1 (970) 498-3058

Distributors & Service
 Woodward has an international network of distributors and service facilities. For your nearest representative, call the Fort Collins plant or see the Worldwide Directory on our website.

Corporate Headquarters
 Rockford IL, USA
 Ph: +1 (815) 877-7441

www.woodward.com

Fuel Type

The TecJet 50 Plus Precision Flow operates on gases ranging from pipeline quality natural gas to propane. Proper application of the valve for fuel flow, FGP, energy content, etc., is the responsibility of the OEM. The fuel gas flowing through the valve can consist of the following compounds with limits if they apply:

Component	Specification Limit
Gaseous hydrocarbons (methane, ethane, propane, etc.):	No limit
Carbon monoxide:	No limit
Carbon dioxide:	No limit
Hydrogen:	<10%
Oxygen:	No limit
Nitrogen:	No limit
Sulfur compounds including hydrogen sulfide:	< 40 mg/10 kWh
Chlorine and fluorine compounds (typically chlorofluorocarbons):	< 100 mg/10 kWh (< 400 mg/10 kWh)
Silicon:	< 5 mg/10 kWh (< 20 mg/10 kWh)
Ammonia:	< 50 mg/10 kWh
Oil or hydrocarbons in liquid (mist form):	< 5 mg/10 kWh
Fine particulates, including silicon (less than 1.0 µm):	< 3 mg/10 kWh

Overall the gas SG should be between 0.4 to 1.6, and the gas energy content between 1 and 9.5 kWh/nm³. The values in () are allowed, but may result in reduced valve life. The above fuel limits can be converted to ppm by multiplying the given number by the LHV of the fuel in question, then dividing by 36. The LHV must be in units of MJ/kg.

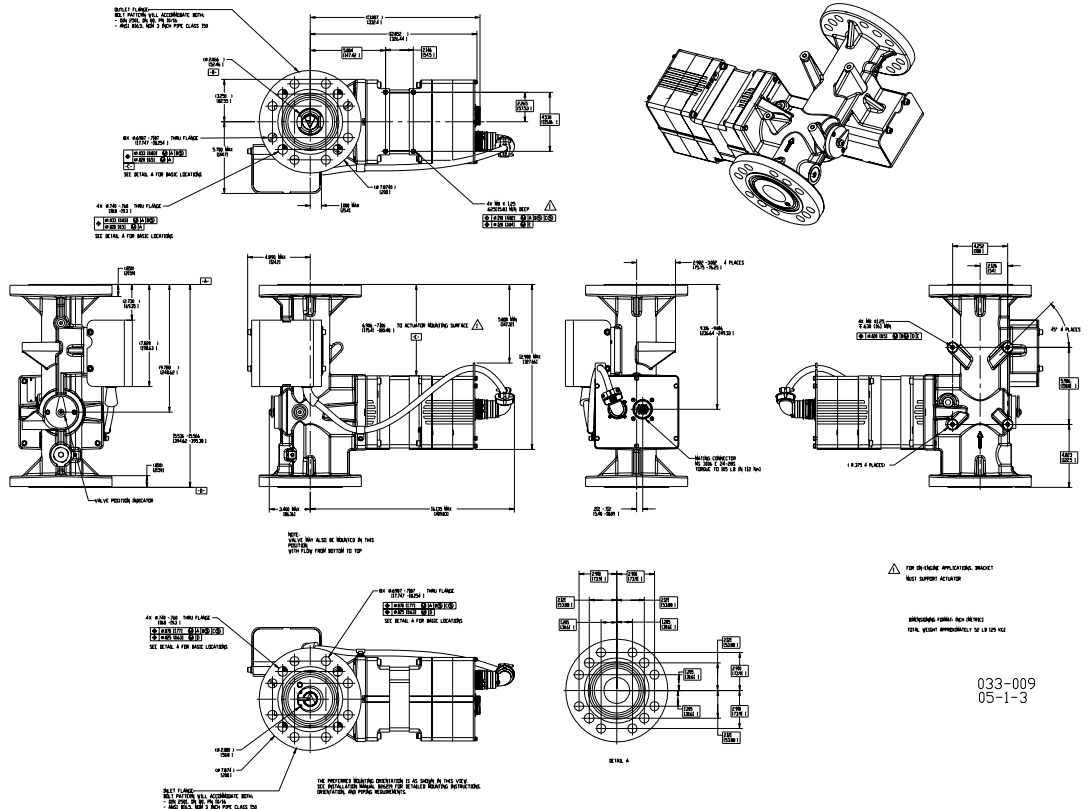

TecJet 50 Plus Precision Flow Outline Drawing
 [Larger scale outline drawing is contained in the technical manual.]

This document is distributed for informational purposes only. It is not to be construed as creating or becoming part of any Woodward Governor Company contractual or warranty obligation unless expressly stated in a written sales contract.