

PGG-EG Governor/Actuator

for electrical generation application

Applications

PGG-EG governor/actuators have motor speed setting of the ballhead backup governor. The units are normally used on generator applications. Externally adjustable droop on the backup governor and load limit are standard on the PGG-EG.

Setting the speed of the mechanical governor slightly higher than the maximum speed under electronic control causes the mechanical portion of the PGG-EG to always seek a fuel setting higher than the electronic control. Electrical control thus controls the fuel position because of the least-fuel-selection feature.

Should the electronic signal to the reverse acting PGG-EG fail, due to some problem in the system, the electric actuator will call for an increased fuel position, above the setting of the mechanical governor. At this point the mechanical speed setting is lower, and the ballhead controls the engine-fuel setting.

PGG governor/actuators are available with any of the PG output systems. Output ranges from 16 N·m (12 lb-ft) maximum work capacity to 678 N·m (500 lb-ft), depending on the governor operating pressure and the output options selected. Most outputs provide 30° of rotary travel (25 mm [1 inch] of linear travel is also available).

PGG-EG governors may be equipped with lube oil pressure and water pressure alarm and shutdown.

Description

The PGG-EG governor/actuator combines the proven dependability of the hydro-mechanical PG governor with the flexibility of an electronic control. The PGG-EG is used to control speed or power output of engines where remote speed-setting capabilities with speed droop on the mechanical side of the governor are required.

The governor has a self-contained oil supply. PGG-EG governor/actuators are available for clockwise, counterclockwise, or reversible drive rotation. Oil pressure is maintained by a relief valve and accumulators. Oil flow to and from the governor power cylinder is controlled either by a centrifugal flyweight and pilot-valve-plunger assembly or by an electronically controlled torque motor and a follower-type pilot valve. The power cylinder is mechanically linked to, and positions, the fuel rack or valve.

Droop in the PGG-EG is set with a dial on the front panel. It is adjustable from 0 to more than 8%. Droop on the PGG-EG is determined by a combination of the dial setting and the position of the governor output cylinder. This allows the mechanical speed to be set closer to the electronic speed than is possible in other "ballhead backup" governor/actuators.

Adjustable load limit makes the PGG flexible in its ability to back up the electrical control and still not overspeed or overload the engine should the electronics fail.

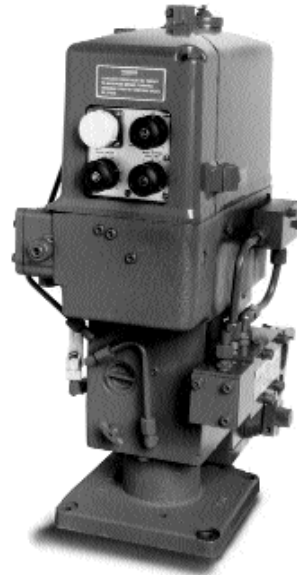

- Compatible with Woodward analog or digital electronic controls
- All PG drives, outputs available
- Vibration-resistant construction
- Adjustable load limit and droop with indicators
- Electrical signal sets mechanical governor speed
- Compliant with applicable CE directives—Machinery Directive

Specifications

Type	12	29	58	200	300	500
Sump Capacity	1.4 L 1.5 qt	1.4 L 1.5 qt	1.4 L 1.5 qt	6.2 L 6.5 qt	6.2 L 6.5 qt	6.6 L 7.0 qt
Maximum Output	16 N·m 12 lb-ft	39 N·m 29 lb-ft	79 N·m 58 lb-ft	237 N·m 175 lb-ft	422 N·m 311 lb-ft	648 N·m 478 lb-ft
Direction of Output	25 mm/1 inch linear or 30° rotary	25 mm/1 inch linear or 30° rotary	25 mm/1 inch linear or 30° rotary	42° rotary	42° rotary	42° rotary
Output Shaft Dimension	0.750-48 serration *	1.000-48 serration	1.000-48 serration	1.125-48 serration	1.500-60 serration	1.500-60 serration
Weight	39–54 kg 85–120 lb	39–54 kg 85–120 lb	39–54 kg 85–120 lb	159 kg 350 lb	159 kg 350 lb	227 kg 500 lb
Maximum Drive Speed Range	200–1600 rpm	200–1600 rpm	200–1600 rpm	200–1600 rpm	200–1600 rpm	200–1600 rpm
Recommended Drive Speed	250–1000 rpm	250–1000 rpm	250–1000 rpm	400–1000 rpm	400–1000 rpm	400–1000 rpm
Internal Hydraulic Pressure	690 kPa 100 psi	690 kPa 100 psi	1724 kPa 250 psi	1379 kPa 200 psi	2482 kPa 360 psi	1931 kPa 280 psi

All standard PG bases are available for PGG-EG 12, 19, and 58 (see manual 36693, *PG Base Assemblies*). PGA-EG 200, 300, and 500 bases have 127 mm (5-inch) pilot diameters and four equally spaced 22.22 mm (0.875 inch) holes on a 353.57 mm (13.920 inch) bolt circle.

* Numerous clevis-type rod ends are available for the linear output systems.

Governor Output

Woodward recommends use of 60% to 70% travel from no load to full load.

Droop Adjustment

Using 270° maximum rotation of the droop adjusting knob (and with typical PG speeder spring and flyweights), droop is infinitely adjustable from 0 to 100 rpm maximum for the full governor stroke.

A positive, minimum position stop provides zero droop at zero droop indicator position (0). Maximum droop is at 10 indicator position.

Load Limit Adjustment

Dial adjustment limits governor power cylinder output to increase fuel. Adjustable from no limiting to shutdown.

Construction

Case and base are cast iron. Internal parts are mild and case-hardened steel.

Description of Operation

The electronic portion of the PGG-EG provides control when the torque-motor beam assumes a new off-center position proportional to a change in the current signal from the electronic governor. The actuator pilot valve will move from its centered position (when centered, the pilot-valve control land covers the control port) to follow the torque-motor beam to its new position. Control pressure oil is then ported to either sump or pressure oil. The output servo will then begin to assume a new position due to the resulting force imbalance. The changing servo position is fed back to the torque-motor beam through the restoring linkage. The restoring linkage acts to return the torque-motor beam and the pilot valve to the centered position. In this position, control pressure is no longer being ported, and the output servo stops moving. If the electronic portion calls for an erroneous high speed (due to power loss, broken wires, etc.), the flyweights will control the mechanical pilot valve and regulate the flow of control pressure oil under the output servo.

Base and Drive Connections

All current PG governor bases can be used with the PGG-EG. **NOTE**—Drive power for different types of PG-EG actuators will vary depending upon speed, internal pump pressure, pump volumetric displacement, pump efficiency, and oil viscosity. Contact Woodward if further information is required.

Regulatory Compliance

Other European Compliance:

Machinery Directive

Compliant as partly completed machinery per 2006/42/EC.

Hydraulic Circuits

The PGG-EG operates from its own sump, using the high-volume PG oil pump and accumulators. The proven PG pump is reversible (for governor drive speed of less than 1000 rpm) or may be set for one-way rotation. A 74 μm, wire-mesh filter is accessible from the outside of the PGG-EG case. The filter protects the small orifice in the pilot valve, which is an integral part of the electric actuator.

The PGG-EG uses SAE 10 to 50 oil, depending on operating temperature. Ambient temperatures limits are -29 to +99 °C (-20 to +210 °F). An oil cooler may be required at upper ambient temperature limits. The hydraulic oil in the governor must be matched to operating temperatures.

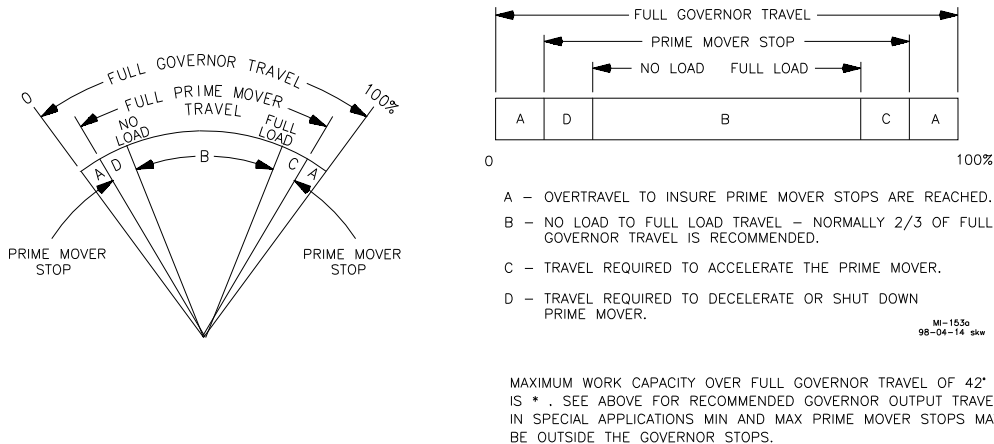

Drive Shaft

1.125-48 serration is standard. Splined or keyed shafts are optional.

Attitude

Vertical

Options

Mode Select Valve and Pressure Switch are optional devices.

PG-EG WITHOUT MODE SELECT VALVE

- SHOWN AT STEADY STATE CONTROLLING ON E.G.
- BALLHEAD PILOT-VALVE OPENED

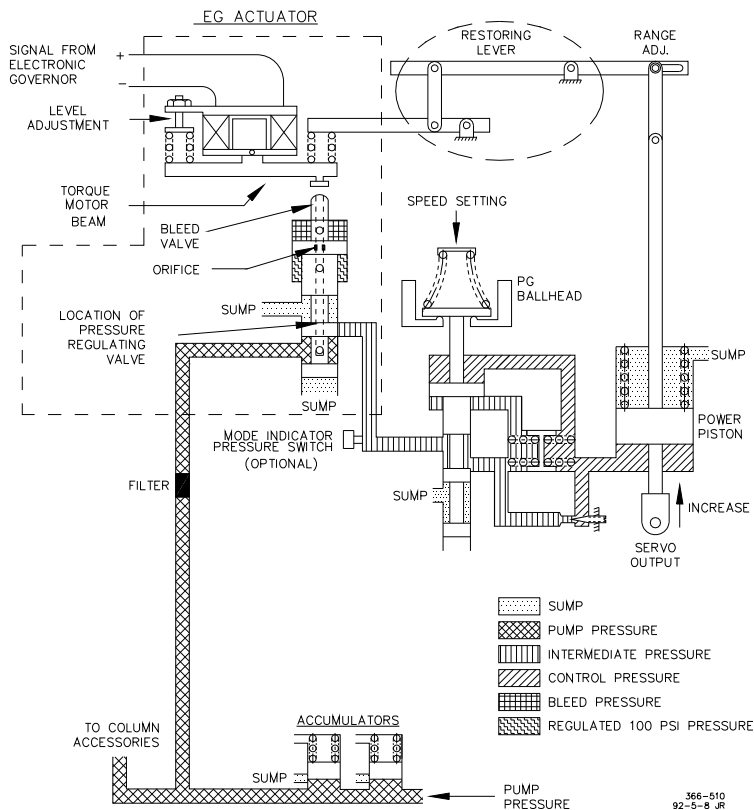

PG-EG Schematic

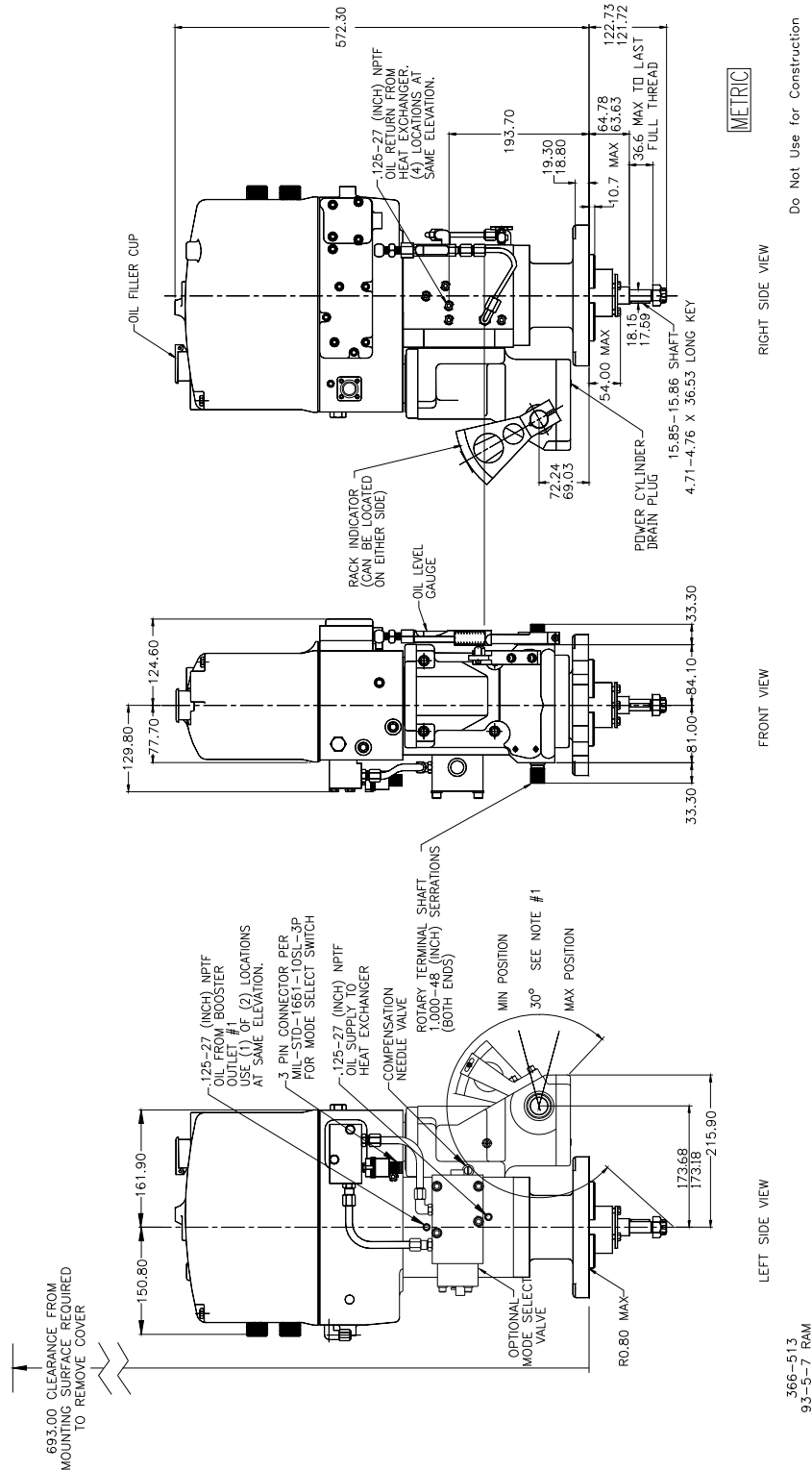

Outline Drawing of a Typical PGG-EG58 Governor/Actuator (Do not use for construction)



PO Box 1519, Fort Collins CO, USA 80522-1519
 1000 East Drake Road, Fort Collins CO 80525
 Tel.: +1 (970) 482-5811 ♦ Fax: +1 (970) 498-3058
www.woodward.com

Distributors & Service

Woodward has an international network of distributors and service facilities. For your nearest representative, call the Fort Collins plant or see the Worldwide Directory on our website.

This document is distributed for informational purposes only. It is not to be construed as creating or becoming part of any Woodward contractual or warranty obligation unless expressly stated in a written sales contract.

Copyright © Woodward 1993-2012, All Rights Reserved

For more information contact: