

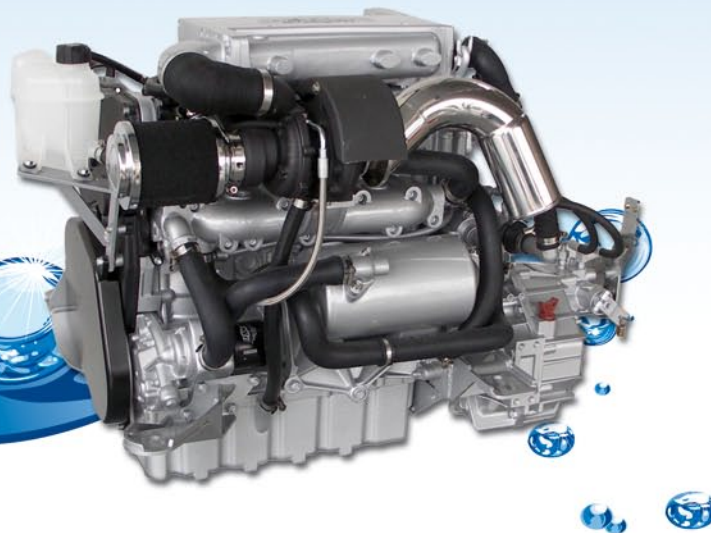

MARINE DIESEL ENGINES

HPE 250



SCHEDA TECNICA | TECHNICAL DETAILS

Configurazione <i>Configuration</i>	4 tempi, doppio asse a camme, 20 V <i>4-stroke cycle, twin camshaft, 20 V</i>
Potenza max all'albero <i>Maximum output at crankshaft</i>	184 kW/250 hp a 4200 giri/min. <i>184 kW/250 hp at 4200 rpm</i>
Potenza max all'elica <i>Maximum output at propeller</i>	177 kW/241 hp a 4200 giri/min. <i>177 kW/241 hp at 4200 rpm</i>
Coppia max <i>Maximum torque</i>	460 Nm a 2600 giri/min. <i>460 Nm at 2600 rpm</i>
Cilindrata totale <i>Displacement</i>	2.387 c.c. <i>2.387 c.c.</i>
Alesaggio per corsa <i>Bore x stroke</i>	82 x 90,4 mm <i>82 x 90,4 mm</i>
Cilindri <i>Cylinders</i>	5, in linea <i>5, in line</i>
Sistema di iniezione <i>Combustion system</i>	Iniezione diretta Common rail <i>Direct injection Common rail</i>
Aspirazione	Sovralimentato con turbocompressore a geometria variabile
<i>Aspiration</i>	<i>Supercharged with variable geometry turbo</i>
Sistema di avviamento <i>Starting system</i>	Motorino di avviamento elettrico 12 V - 2,1 kW <i>Electric starting 12 V - 2,1 kW</i>
Alternatore <i>Alternator</i>	12 V - 140 A <i>12 V - 140 A</i>
Sistema di raffreddamento	Doppio circuito con scambiatore di calore
<i>Cooling system</i>	<i>Double water cooling system with heat exchanger</i>
Sistema di lubrificazione <i>Lubrication system</i>	Forzata con pompa ad ingranaggi <i>Forced lubricating system with pump</i>
Max inclinazione di montaggio <i>Max. mounting inclination</i>	14° <i>14°</i>
Peso a secco senza invertitore <i>Dry weight without gear</i>	290 kg <i>290 kg</i>
Supporti motore <i>Engine mounting</i>	Supporti elastici anti-vibranti <i>Rubber type anti-vibration mounting</i>
Certificazione <i>Environmental</i>	RCD 2003/44/CE ed EPA TIER 2 <i>RCD 2003/44/CE and EPA TIER 2</i>

**POTENZE SECONDO ISO 8665, COMBUSTIBILE DIESEL EN 590, TOLLERANZA SULLA POTENZA 5%
POWER ACCORDING ISO 8665, TOLERANCE 5%, DIESEL FUEL ACCORDING EN 590**

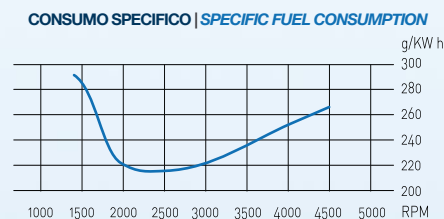
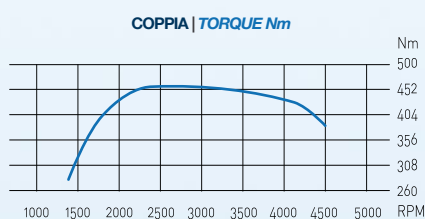
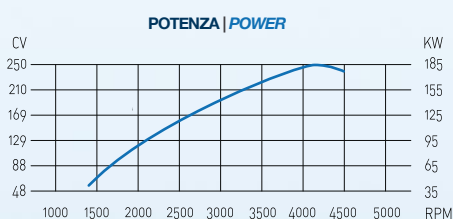

DIMENSIONI MOTORE | ENGINE DIMENSIONS

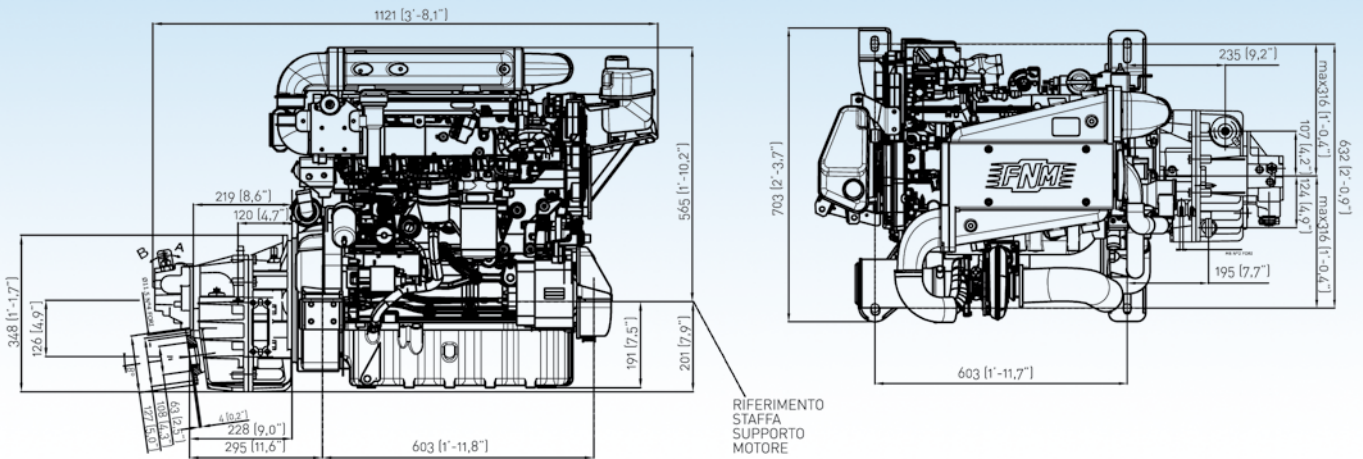

FNM HPE 250 con invertitore ZF 45 A | FNM HPE 250 with ZF 45 A gearbox
 Disponibile anche con invertitore TM 485 A | Available also with TM 485 A gearbox
 Diametro gomito di scarico 90 mm | Exhaust riser diameter 90 mm
 Diametro ingresso gasolio 8 mm | Fuel line inlet diameter 8 mm
 Diametro ingresso acqua mare 32 mm | Sea water line inlet diameter 32 mm

QUADRO STRUMENTAZIONE | INSTRUMENT PANEL

- Pressione olio | Oil pressure
- Temperatura acqua | Water temperature
- Voltmetro | Voltmeter
- Contagiri | Rpm counter
- Cablaggio 8 metri | 8 meter cable



ACCESSORI DOTAZIONI STANDARD | ACCESSORIES STANDARD PACKAGE

- Invertitore idraulico | Hydraulic gearbox
- Supporti elastici | Set of flexible mounts
- Alternatore auto regolato 12 V - 140 A
- Alternator 12 V - 140 A with built-in regulator
- Motorino avviamento 12 V - 2,1 kW | Starter motor 12 V - 2,1 kW
- Filtri olio e combustibile | Oil and fuel filters
- Gomito scarico inox refrigerato
- Stainless steel seawater-cooled elbow
- Filtri Racor | Racor filters
- Quadro strumentazione con 8 mt. cablaggio
- Instrument panel with 8 mt. cable
- Pompa acqua mare in bronzo | Bronze seawater pump
- Cover motore | Engine top cover
- Collettore scarico refrigerato | Water-cooled exhaust manifold

OPTIONAL | OPTIONAL

- Kit tubazioni per riscaldamento interno imbarcazione | Kit for boat internal heating
- Cablaggio ausiliario 2 mt. | 2 mt. auxiliary extension cable
- Quadro flybridge con 8 mt. cablaggio | Flybridge instrument panel with 8 mt. cable
- Kit per connessione piede poppiero a Mercurier a Volvo | Kit for coupling to Mercurier and Volvo stern drives
- Trolling valve | Trolling valve
- Puleggia anteriore a due gole libere | 2-groove front pulley

