

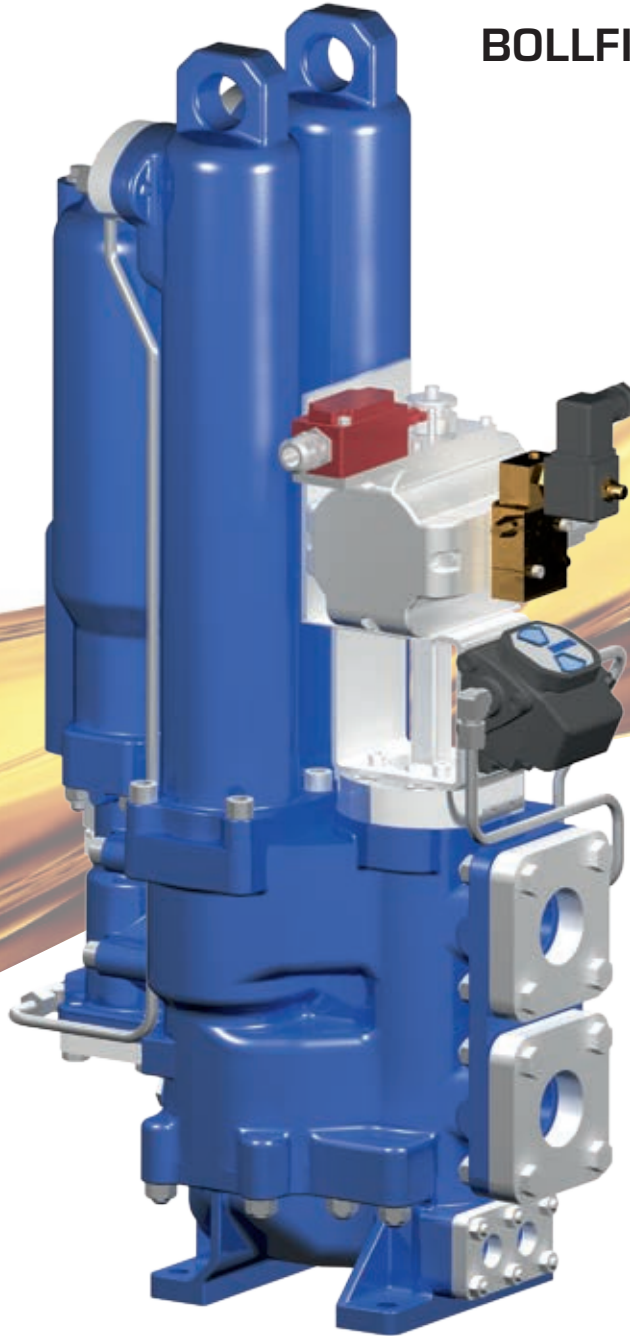

BOLLFILTER
Protection Systems

Marine & Power

**BOLLFILTER Automatic
TYPE 6.72**



*The Compact Design
Two-Chamber Filter*

Perfect pre-treatment

In order to ensure that large combustion engines operate for long periods of time without problems and interruptions, the fuels, lubricants have to fulfil defined quality requirements. The heavy fuel oil operation of engines also requires an extensive pre-treatment of the fuel. In all cases, filtration plays a key role. The special filters installed in the inlet systems and liquid circuits must

- through their capacity guarantee the supply of sufficient amounts of liquid,
- guarantee a high degree of purity of the fuel, in order to protect the injection system against wear,
- through their design and dimensioning ensure the constant operating pressure,
- even in the case of varying fuel qualities ensure a problem-free continuous operation and
- through maintenance-free operation and a long service life contribute to keeping operating costs low.



The BOLLFILTER Automatic TYPE 6.72 provides excellent results for the filtration of fuels and lubricants for mobile



and stationary drives.

Filtration and regeneration without interruption

The BOLLFILTER Automatic TYPE 6.72 optimally fulfils the tasks described above. It does so thanks to a special design that features two chambers in which the functions of filtration and regeneration are carried out simultaneously and separately. Two filter chambers are mounted on top of the filter housing. Each of these chambers is fitted with a vertically positioned filter element and between 1 and 16 filter candles. Dividing up the work among themselves, they act as a uniform system. The filtering work is divided up in such a way that at any one time one of the filter chambers can regenerate while the other carries on filtering. In the event of the capacity of the filter candles in the filter chamber that is currently operating being contaminated, the regenerated reserve element will take over. The indicator for the contamination is the pressure differential between the dirty and the clean side. Regeneration is carried out efficiently and extremely fast, assisted by compressed air, in a manner that prevents the mesh from being damaged. The system pressure remains at a constant level and the flushing volumes are very low.

For heavy fuel oil operations an additional heating chamber can be integrated into the housing. The heating chamber sees to it that the outflowing cleaned liquid maintains the temperature required for its subsequent application.



Monitoring and control

The fully automatic filter complies with the regulations of the following Marine Standards Authorities (GL, LRS, NV, BV, ABS, USCG etc.) for unsupervised operation onboard ship.

The standard equipment of the backflushing filter includes an Electronic Control Box Type 2200 with the following features and functions:

- membrane keypad with three keys,
- 2-line display,
- impact-resistant display cover,
- display of backflushing operation, number of backflushes and error messages,
- adjustable over current release,
- CPU card with non-volatile EPROM and program memory,
- I/O board in control box,
- main switch with interlocking system

Fuel System for Heavy Fuel Operation

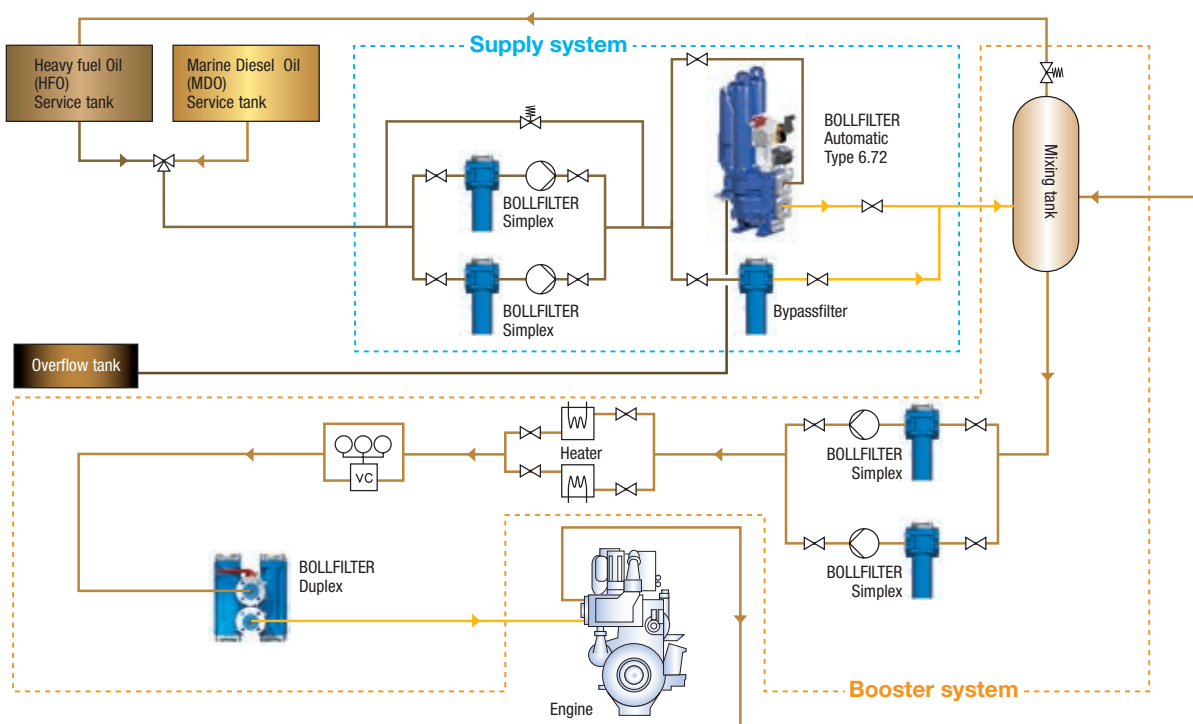

Backflushing in tandem with filtration

During the filtration process, the liquid to be filtered will flow through the inlet opening ① into the filter housing. The liquid is fed into the chamber that is engaged ② passing through the filter candles ③ from the outside to the inside. The solids being filtered out are held back by the mesh. The cleaned liquid ④ passes through the inside of the candle to the filter outlet in the lower part of the housing. During this filtration process, one filter element with clean filter candles will be on hold as a reserve in the chamber that is not involved in the current operation. The backflush discharge valve is shut and compressed air is available in the air reservoir. Once the differential pressure between the dirty and clean sides of the filter has, through the contamination on the mesh, reached a predetermined value, the filter element cleaning process is actuated automatically. The pneumatic drive ⑤ will then swivel the actuating device to a point where the inflow of unfiltered liquid into the contaminated filter chamber is blocked

while the inflow into the chamber with the reserve candles is enabled at the same time. This will cause the differential pressure to drop immediately. At one and the same time a double-acting tappet ⑥ then opens the opening for the flushing oil outlet ⑦ and the infeed for the flushing air ⑧. The flushing air from the air reservoir ⑨ will expand explosively and press clean liquid at a high speed in reverse direction ⑩ through the filter candle. The particles on the outside of the candle are thereby removed and flushed out of the filter via the open backflush discharge valve ⑪.

After a short after-blowing time, the backflush discharge valve will close again. The emptied chamber will be filled with clean liquid via a refill bore. The candles in this chamber are now the reserve that is ready and waiting to be once again switched into the filtering process.

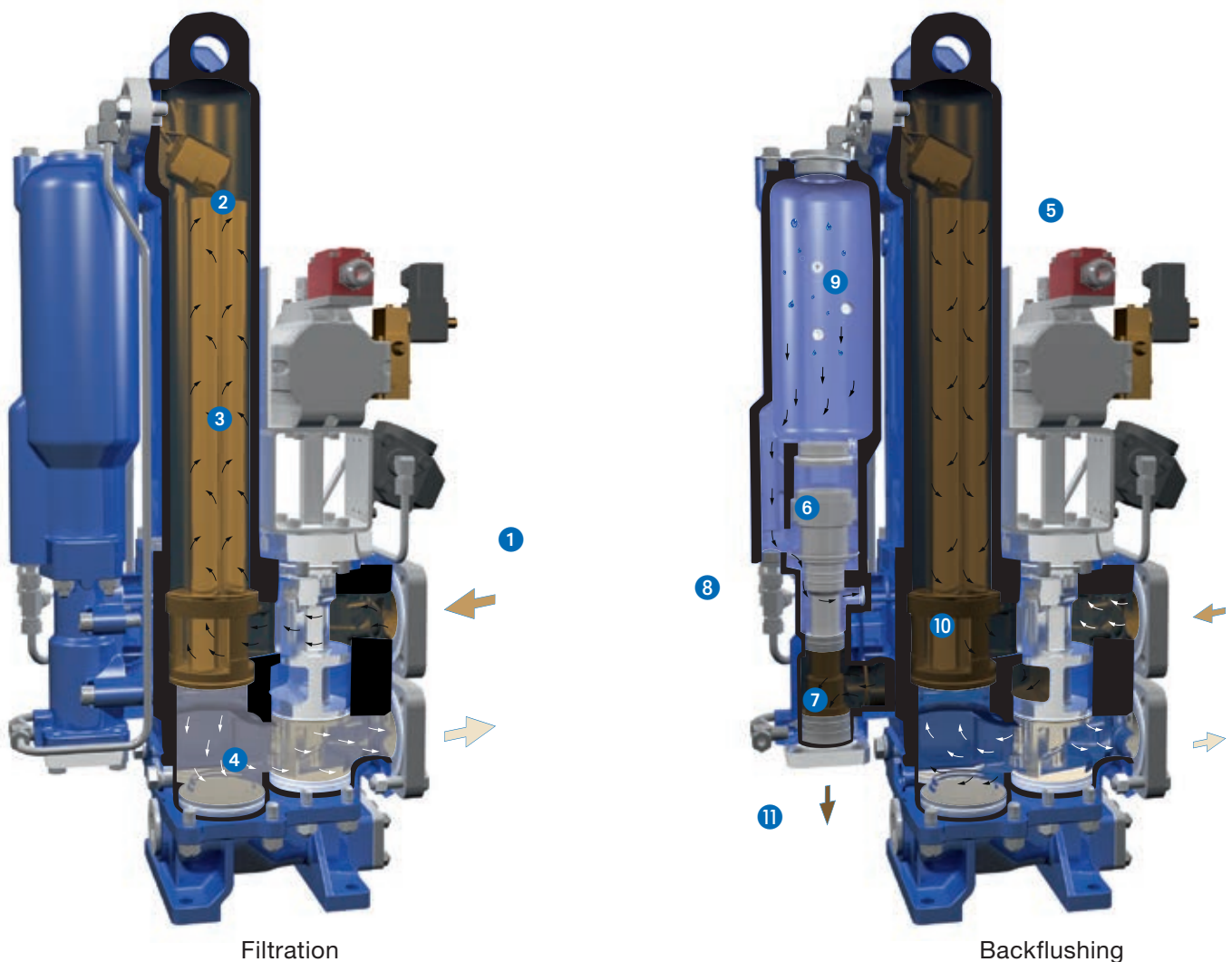

The accessories

Useful and functional

In line with their requirements users can, with the help of certain accessory items, modify the configuration of their BOLLFILTER Automatic TYPE 6.72.

Thus it is possible to equip the filter with a heating chamber designed to be integrated into the bottom fastening of the filter housing. The filter can be equipped with an additional by-pass filter with an integrated change-over cock. This configuration is available with and without a heating chamber (rotatable by 90°).

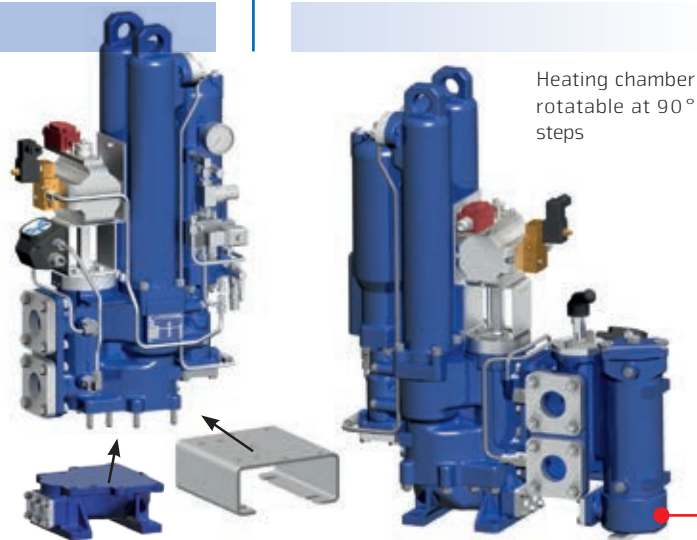

Heating chamber rotatable at 90° steps

Bottom fastening with heating chamber (figure on the left) and without heating chamber (figure on the right)

BOLLFILTER Automatic with change-over cock and by-pass filter and with integrated heating chamber (TYPE 6.72.1)

The details

Data and facts at a glance

BOLLFILTER Automatic TYPE 6.72	Multichamber automatic filter with compressed-air backflushing
Range of application	Heavy fuel oil, diesel oil, lubricating oil
Max. operating pressure	16 bar
Max. operating temperature	160 °C
Housing material	EN – GJS – 400 -15
Nominal width of connection flanges	DN 40, DN 65 or DN 80
Filter candle type / mesh type	Cylindrical screw-in candles or star candles with woven mesh
Grade of filtration	6 microns
Cleaning	Sequential reverse-flow backflushing, assisted by compressed air
Backflushing control	Differential pressure-dependent or time-dependent



Technical data			
Filter size	DN 40	DN 65	DN 80
Total no. of filter chambers	2	2	2
No. of filter chambers in operation	1	1	1
Cylindrical screw-in candles			
Total number	6	16	32
Total filtration area in cm ²	2,208	5,888	11,776
Filtration area in use in cm ²	1,104	2,944	5,888
Star candles			
Total number	2	6	10
Total filtration area in cm ²	4,800	14,400	24,000
Filtration area in use in cm ²	2,400	7,200	12,000

Convincing in every respect

Numerous innovative details contribute to the superior performance, reliability and efficiency of the BOLLFILTER Automatic TYPE 6.72. Among the most important improvements are:

- space savings thanks to compact housing,
- improved durability through a sturdy design, less assemblies and movable parts and a connection to the air reservoir without piping,
- perfect synchronisation of the backflushing process due to the double-acting air/flushing valve,
- easy access to the filter elements thanks to the quick-release covers,
- low maintenance due to an innovative design with less wear parts,
- exclusion of malfunction risks leading to an increase in the availability of the plant.

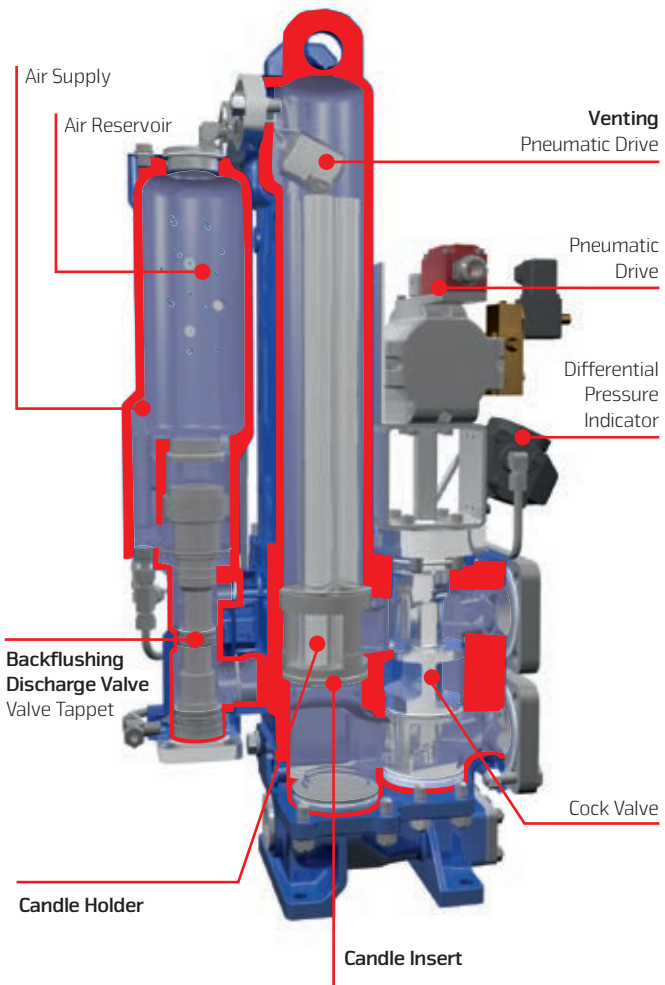

Maximum customer orientation for maximum satisfaction

BOLL & KIRCH continues to prove its strengths as a manufacturer and supplier of filters long after the product has been delivered. As a leading international supplier of marine and industrial filters for filtering fuels, lubricants, coolants and water with a global network of sales and service centers in five continents, BOLL &

KIRCH has at its fingertips the ideal logistical basis for providing perfect customer support. Naturally, users of the BOLLFILTER Automatic TYPE 6.72 also benefit from the advantages this worldwide network provides – swift delivery, faster availability of technical support and a trouble-free supply of replacement parts.



BOLL & KIRCH Filterbau GmbH

Postfach 14 20 • 50143 Kerpen • Germany
 Siemensstraße 10-14 • 50170 Kerpen • Germany
 Tel.: +49 2273 562-0
 Fax: +49 2273 562-223
 e-mail: info@bollfilter.de
 internet: www.bollfilter.de