

# Vertex Compressor Control

## Applications

The Vertex control is designed to control and protect industrial sized axial or centrifugal compressors. This controller includes specifically designed algorithms and logic to start, stop, control, and protect industrial compressors driven by a stationary speed motors, variable frequency drive motors, or turbines. OEM qualified algorithms are used within the Vertex control for straight-through, iso-cooled, double flow, stand alone, and back-to-back compressor applications.

The Vertex controller is field configurable allowing users to configure/select the specific control algorithm required for the specific compressor loop and application. The control's special stage-to-stage and performance controller decoupling logic allows stable control during normal compressor operation as well as during plant upsets, minimizing process over or undershoot conditions.

This purpose-built controller has the control, protection, and decoupling logic required for one or two recycle loop compressor applications. OEM qualified algorithms are used to ensure that proper start sequences are followed, proper and accurate compressor load calculations are used, and proper protection and recovery actions are performed.

Basic functionality includes:

- Motor or Turbine Drive Interface Logic
- Inlet Throttle Valve Control
- Inlet Guide Vane Control
- Recycle Valve(s) Control
- Anti-Surge Control (1 or 2 Recycle Loops)
- Performance Control (suction or discharge pressure or process flow)
- Surge Anticipation Logic
- Surge Protection Logic
- Surge Recovery Logic
- Load Sharing (Parallel compressors, up to five Trains)

Optionally users can apply Vertex controllers in simplex or dual-redundant controller configurations. When applied in simplex configurations, a single Vertex controller is used to control and protect the compressor. When applied in dual-redundant controller configurations, two Vertex controllers are connected together in a parallel fashion with one unit functioning as the system controller (SYSCON), and one unit functioning as the backup controller (BACKUP). With dual-redundant configurations, transfer from the SYSCON to BACKUP controller is performed automatically upon a SYSCON failure, or manually by an operator for system and transfer verification purposes.



- Field Configurable
- Integrated graphical operator control panel
- Simple to install, configure & operate
- Integrated compressor and performance control functions
- Simplex or Dual-Redundant models available
- First-out problem indicator (Alarm & Trip Logs)
- Trip and Alarm event recorder
- On-Line Anti-Surge Valve Test Routine
- Real-time clock synchronization via SNTP
- Ethernet & Serial communications
- Expandable I/O via distributed modules
- Sulfur-resistant conformal coating
- Certified for Hazardous Locations
- Load sharing up to 5 Trains.

In dual-redundant applications, depending on system design, anti-surge valve movement during SYSCON and BACKUP controller transfer can either be bumpless (no-movement) or up to ~80 milliseconds in the open direction. To ensure system up-time with dual-redundant applications either Vertex controller (SYSCON or BACKUP) can be repaired and or replaced with the compressor operating on-line normally.

For applications where the compressor's anti-surge valve (ASV) stays closed for long periods of time, the Vertex includes a special on-line ASV test routine to test and verify valve movement with little or no effect on compressor or process operation. With this special ASV test routine plant operators can now verify ASV health and performance without reducing production levels or effecting system availability.

Designed to function as a plant DCS node the Vertex controller can be configured to interface with the plant DCS via hardwired inputs/output signals or serial or Ethernet communications. With the capability to monitor and control all compressor based functions (i.e. bearing temperatures, vibration levels, control oil levels, etc.) the Vertex controller is ideal for use as a cost-effective compressor control/protection as well as a plant DCS monitoring node.

Designed to replace old obsolete anti-surge controllers, the Vertex can be configured to function like these controllers but uses faster scan rates, improved surge anticipation logic, and one integrated package for all control functions (anti-surge control loop 1, anti-surge control loop 2, and performance control). Also, for load sharing function, no need for additional Master controller hardware.

## Description

---

The Vertex control is packaged in an industrial hardened enclosure designed to be mounted within a system control panel located in a plant control room or next to the compressor. The control's user-friendly front panel serves as both a programming station and operator control panel (OCP). This user-friendly front panel allows engineers to access and program the unit to the specific plant's requirements, and plant operators to easily start/stop the compressor and enable/disable any control mode. The controller's 8" graphical display allows operators to view actual and setpoint values from the same screen, simplifying compressor operation.

The control's front panel serves as both a programming station and OCP. Password security is used to protect all unit program mode settings. The controller's 8" graphical display allows operators to view actual and setpoint values from the same screen, simplifying turbine operation.

With dual-redundant Vertex controller applications, the front panels of both units function as redundant operator control panels and can be utilized to manage and monitor compressor operation.

Ethernet and serial communications allow users to easily connect the Vertex in to plant or process control system. All controller inputs, outputs, and statuses can be monitored and all start/stop or enable/disable commands can be given through industry standard Modbus TCP or OPC protocols. The Vertex control uses SNTP (synchronized network time protocol) over Ethernet to allow users to synchronize the control's real-time clock to the plant distributed control system.

Compressor and motor interface input and output-wiring access is located on the controller's lower back panel. Un-pluggable terminal blocks allow for easy system installation, troubleshooting, and replacement. Optionally users can increase the number of inputs and outputs signals to/from the Vertex control by connecting RTCNet distributed I/O nodes to the controller's CAN communication ports and configuring the control to use the connected distribute inputs and outputs. The following additional I/O signals can be connected to the Vertex control via CAN communications:

(16) 4-20mA input channels and (4) 4-20mA output channels (via 2 RTCNet AIO module)

(8) RTD signals (via 1 RTCNet RTD module)

(16) Discrete Inputs (via 1 RTCNet DI module)

(16) Relay output drivers (via 1 RTCNet DO module)

The Vertex controller includes the following PID control & protection functions:

Performance Control PID	Rate PID Control
Performance Limiter PID	Boost (open-loop backup line response)
Anti-Surge PID Control	Surge Recovery
Surge Minimum Position	Start, Purge, Stop, Shutdown, & Zero Speed Sequencing Positions
Alarm & Shutdown Logic	Load sharing among 5 trains with no additional hardware for Master Controller.
Easy Load sharing setup. (Plug and Play configuration).	
Independent PID (gland seal steam, other)	

Optionally users can utilize Woodward's RemoteView software program with the Vertex control to function as a remote operator control panel and or engineering station. This software program once loaded onto a remote computer or touch panel, allows the user to perform all of the Vertex control's front panel display functions (monitor, operate, tune, and configure) on the respective computer or touch panel. Password based login level security is utilized with this software program to allow users to manage what functions they want the remote panel user to have.

The Vertex controller includes a suite of service tools to allow users to perform the following functions:

Upload configuration settings files from the Vertex to save on another device

Download configuration settings files to the Vertex

Download and view DataLog files

View real-time or saved trend files



Figure 1. Example RemoteView Screens

## Specifications

**Cost-Effective Design**—The Vertex control is designed to function as the compressor control, performance control, anti-surge control, system sequencer, operator control panel, and first-out indicator. This encompassing design minimizes external system devices as well as system installation, wiring, and troubleshooting.

This field configurable controller allows major functional changes to be made at site, often by knowledgeable plant personnel, and minor functional changes to be on-line as process changes require. The Vertex control's first-out-indicator logic indicates internal as well as external system related alarm and shutdown conditions, greatly simplifying and reducing system troubleshooting.

**Communications**—The Vertex control can communicate directly with plant Distributed Control Systems and/or operator control panels, through Ethernet ports using Modbus TCP or OPC communication protocols, or via one serial Modbus port. The single serial port supports RS-232 or RS-485 communications using ASCII or RTU Modbus protocols.

Communications between the Vertex and a plant DCS can also be performed through hardwired connections.

Internal communication between Vertex units for Load sharing communication is through UDP protocol.

### System Protection

- Anti-surge protection (1 or 2 recycle loops)
- Boost (open-loop backup line response)
- Surge Detection
- Surge Recovery
- Surge Minimum Position
- First-out Indication (alarm & trip inputs)
- Bearing temperature alarm and trip settings
- Compressor vibration alarm and trip settings
- Control CPU & memory failure detection logic
- Mode login level password security

**Control**—The following PIDs /controls are available for use in controlling and protecting the compressor train:

- Anti-Surge PID Control
- Rate PID Control
- Performance PID Control
- Load sharing controller
- Independent PID
- Start, Purge, Stop, Shutdown, & Zero Speed Sequencing Positions
- Alarm & Shutdown Logic

## Control Specifications

### INPUTS

Power:	LV models = 18 - 36Vdc HV models = 88 - 264Vac & 90-150Vdc (50 watts max)
Speed:	(2) Passive MPU's or 2 Active Proximity probes (0.5 – 32,000 Hz)
Discrete Inputs:	(19) Configurable Contact Inputs (optionally (16) additional inputs via RTCNet module)
Analog Inputs:	(8) Configurable 4-20mA Inputs (optionally (16) additional inputs via RTCNet module)

### OUTPUTS

Valve/Actuator Drivers:	(2) Actuator Output, 4-20mA or 20-200mA
Discrete Outputs:	(7) Relay Outputs (24Vdc @ 2 amps, Form-C contacts) (optionally 16 additional outputs via RTCNet module)
Analog Outputs:	(6) 4-20 mA Outputs (optionally 4 additional outputs via RTCNet modules)

### COMMUNICATIONS

Ethernet:	(3) customer ports (Modbus TCP or OPC) Simplex versions, (2) customer ports (Modbus TCP or OPC) Redundant versions, (1) Port Service Tool use
Serial:	1 Modbus port (ASCII or RTU) Comm Ports (RS-232 or RS-485 compatible)
CAN:	(4) ports (RTCNet comm. protocol)

## Features

- Configurable for dual-redundant applications
- Integrated operator control panel
- Surge prevention, detection & recovery logic
- Security (program is password protected)
- First-Out indication (alarms & shutdowns)
- On-line Anti-Surge Valve Health Test
- Remote analog setpoints for Performance control
- Bearing temperature monitoring/alarms/trips
- Vibration monitoring/alarms/trips

## Regulatory Compliance

### European Compliance for CE Marking

These listings are limited to only those units bearing the CE Marking.

- EMC Directive: 2014/30/EU COUNCIL DIRECTIVE
- LVD Directive: 2014/35/EU COUNCIL DIRECTIVE
- ATEX Directive: 2014/34/EU COUNCIL DIRECTIVE 2, Category 3, Group IIG Ex ic nA IIC T4 X Gc IP20

### Other International Compliance

- IECEx Ex ic nA IIC T4 Gc: Certificate No. IECEx CSA 15.0020X

### North American Compliance

- CSA Listed for Ordinary Locations Certificate 70006135 (LR 79726)
- CSA Listed for Class I, Division 2, Groups A, B, C, and D, T4 at +70 °C: Certificate 70006135 (LR 79726)

## Control Accessories

**RTCNet Modules**—Optionally users can apply Woodward distributed I/O modules to extend the Vertex controller's input and output channels

**Vibration Sensor Kit**—Optionally users can apply 4-20mA accelerometer sensors with the Vertex to monitor unit vibration levels and alarm & trip on high vibration events. Refer to product manual for related kit part numbers

**RemoteView**—Woodward's RemoteView software program once installed on a computer or touch panel can be used as an engineering workstation and or remote operator control panel.

**Stored Trend/Log File Service Tool** – Woodward's Control Assistant software service tool can be used to view real-time trends, saved trend files, upload and download Vertex control's configuration files and alarm/trip logs

## Operating Conditions

- –30 to +70 °C ambient air temperature range
- Humidity: Lloyd's ENV2 test #1
- Dry Heat: Lloyd's ENV3
- Salt Fog: US MIL-STD-810 method 509.2 procedure 1
- Shock: meets US MIL-STD-810C, method 516.2-1, procedure 1B
- Vibration: Lloyd's ENV2 test #1

## Pollution Resistance

- Particulate Pollution Resistance: IEC 60664-1 Pollution Degree 2 (normally only non-conductive pollution occurs)
- IEC 60068-2-60:1995 Part 2.60 Methods 1 and 4 (Flowing Mixed Gas Corrosion Test)
- Gaseous Pollution Resistance: Module conformal coating withstands NO<sub>2</sub>, CO<sub>2</sub>, SO<sub>2</sub>, and H<sub>2</sub>S gases
- Will withstand levels typical of telecommunications and computer installations as defined by Battelle Labs Class III (between
- IEC60721-3-3 classification 3C1 and 3C2, light industrial to urban industrial, heavy traffic)

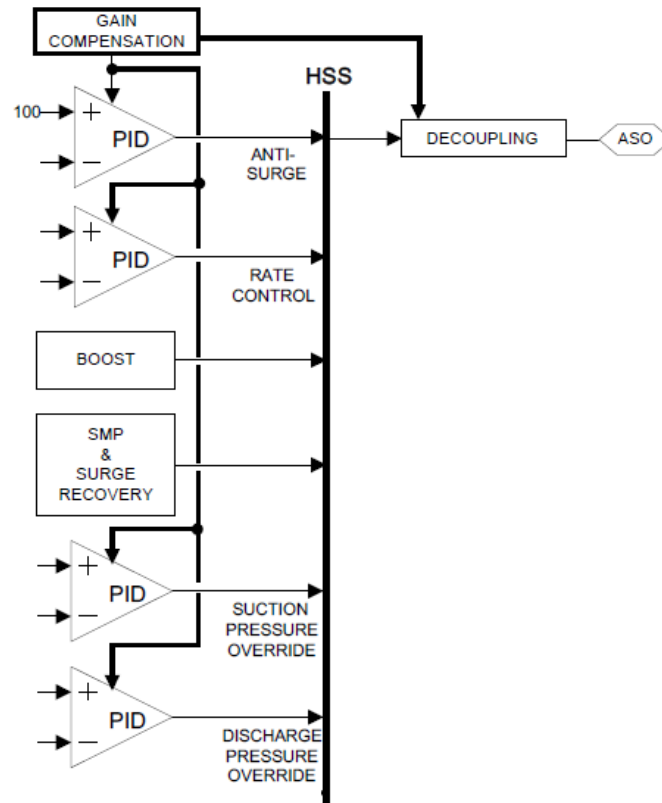

Figure 2. Basic Functional Control Diagram

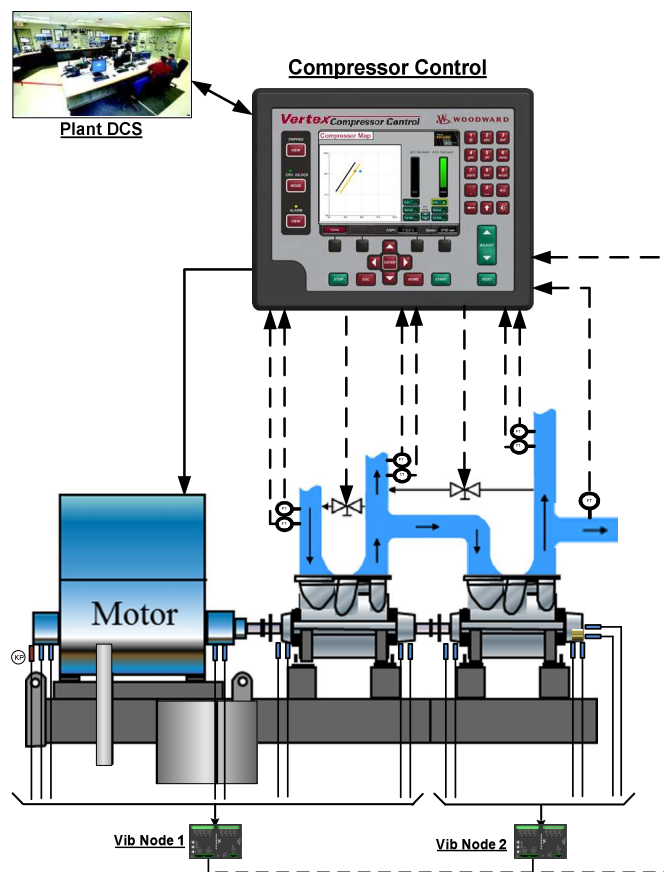

Figure 3. Typical Motor Driven Compressor Application (with two recycle loops configured)

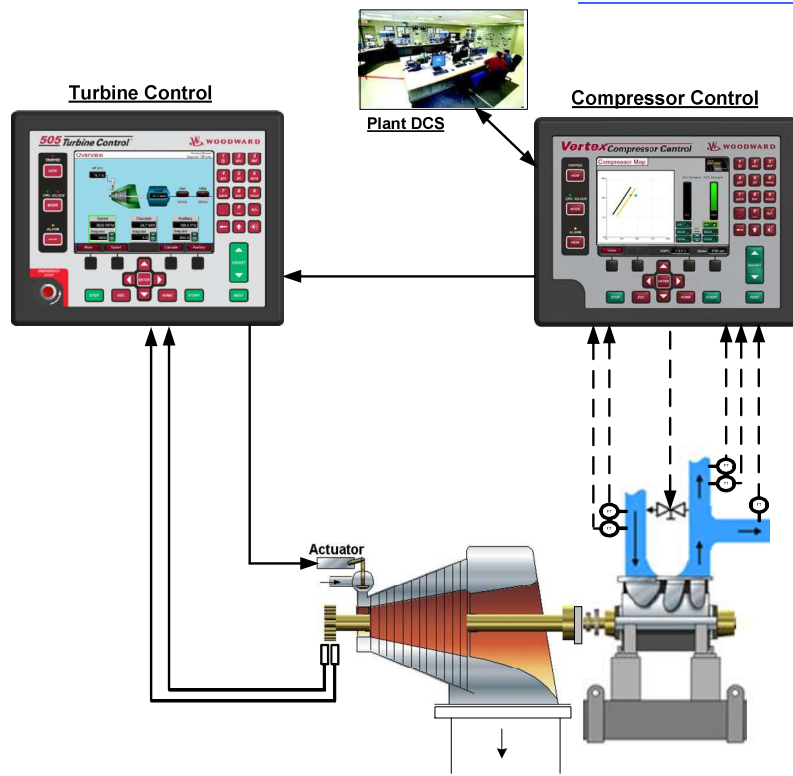

Figure 4. Typical Turbine Driven Compressor Application (with one recycle loop configured)

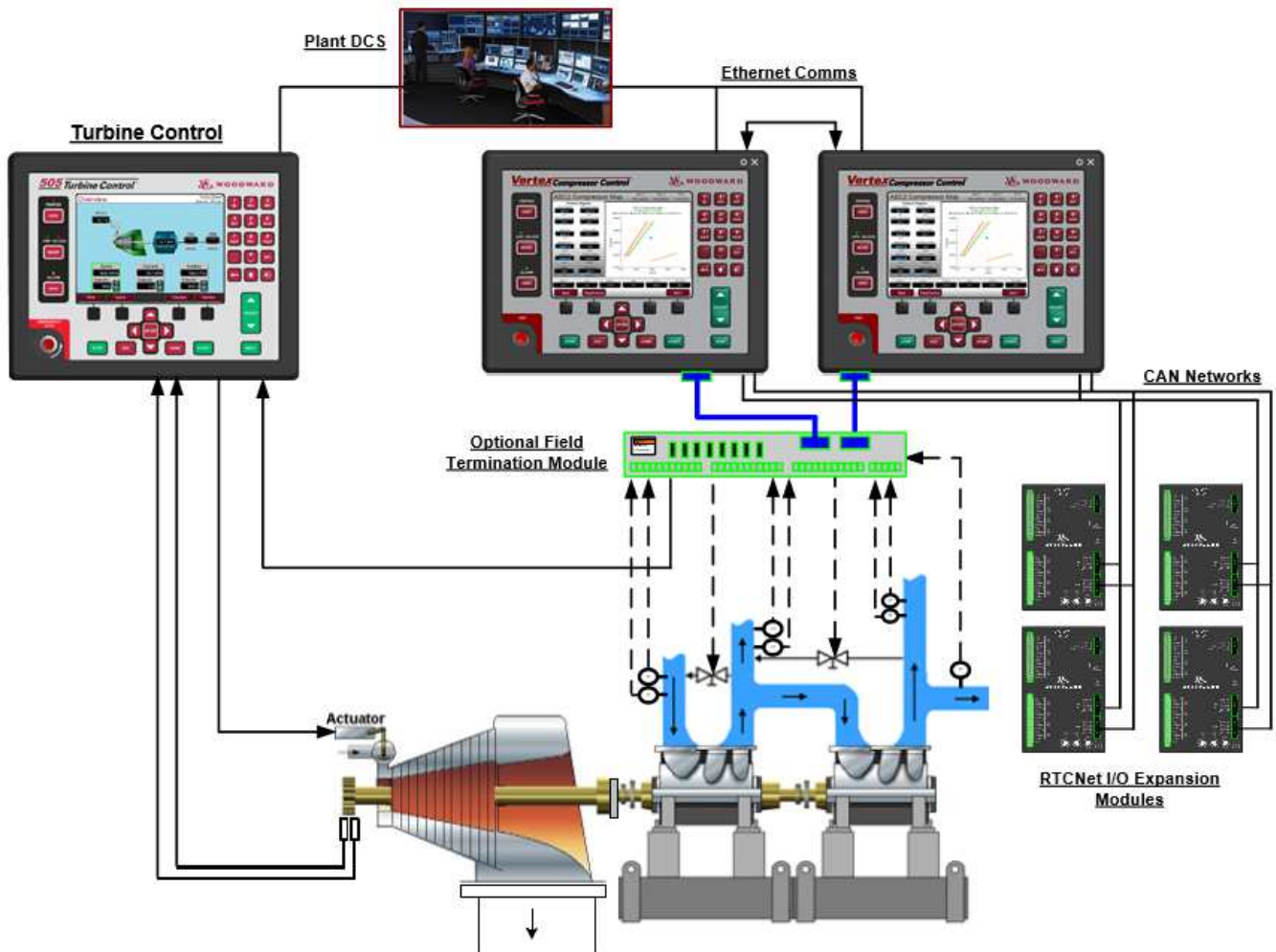

Figure 5. Typical Dual-Redundant Vertex Control Application

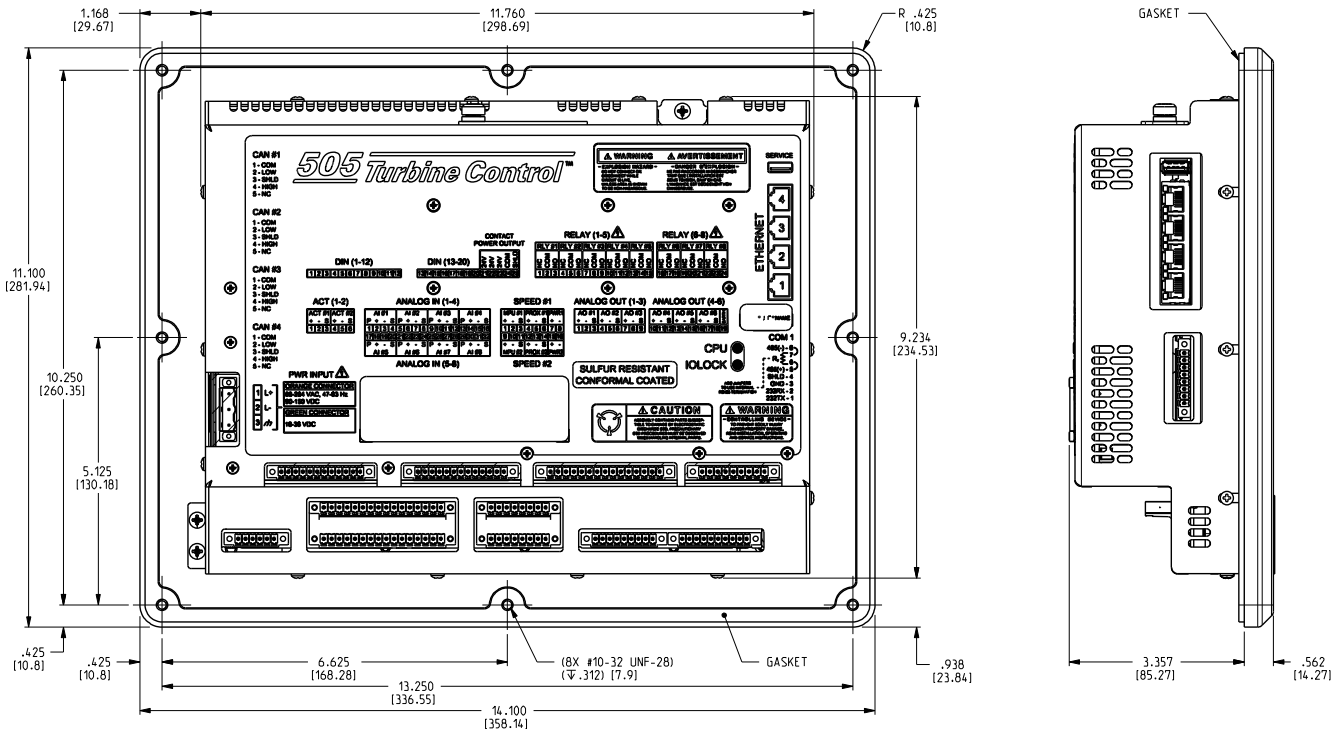

Figure 6. Vertex Control Package Dimensions



PO Box 1519, Fort Collins CO, USA 80522-1519  
 1041 Woodward Way, Fort Collins CO 80524  
 Tel.: +1 (970) 482-5811  
[www.woodward.com](http://www.woodward.com)

**Distributors & Service**

Woodward has an international network of distributors and service facilities. For your nearest representative, call the Fort Collins plant or see the Worldwide Directory on our website.

This document is distributed for informational purposes only. It is not to be construed as creating or becoming part of any Woodward contractual or warranty obligation unless expressly stated in a written sales contract.

Copyright © Woodward 2016–2020, All Rights Reserved

For more information contact:

